

M SERIES ABRASIVE BLASTER

OPERATION AND MAINTENANCE MANUAL

JULY 2007

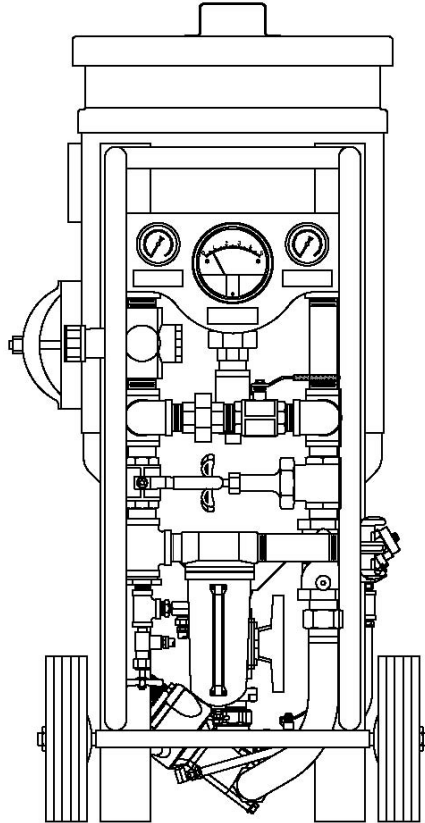

SCHMIDT®

SAVE THIS MANUAL AND MAKE AVAILABLE
TO ALL USERS OF THIS EQUIPMENT!

Manual Part Number 7200-285



AXXIOM Manufacturing, Inc.
11927 S. Highway 6, Fresno, Texas 77545
800.231.2085 * 281.431.0581 * fax 281.431.1717



WARNING

- 1. Any person intending to operate this equipment or any person intending to be in the vicinity during its operation must receive proper training from his/her supervisor, employer and/or supplier. If this equipment is to be leased or rented, the supplier must assure that the lessee or renter has received proper training before the lessee or renter takes possession of the equipment. Consult Axxiom Manufacturing, Inc.**
- 2. Any person authorized to operate this equipment or any person intending to be in the vicinity during its operation and who is not capable of reading and understanding this manual must be fully trained regarding the *Rules for Safer Operation* and all operating procedures and must be made aware of all the Dangers, Warnings, and Cautions identified herein. Consult Axxiom Manufacturing, Inc.**
- 3. Do Not operate any abrasive blaster or blast equipment before reading and completely understanding all the warnings, operating procedures and instructions, and the *Rules for Safer Operation* contained in this manual.**
- 4. Do Not operate any abrasive blaster or blast equipment without following the *Rules for Safer Operation* and all the operating procedures and instructions. Failure to properly use blast equipment could result in serious injury or death.**
- 5. Do Not perform any maintenance on any abrasive blaster or blast equipment while it is pressurized. Always depressurize the abrasive blaster vessel before loading abrasive or performing any maintenance.**
- 6. Do Not use abrasives containing free silica. Silica can cause silicosis or other related respiratory damage. You must wear personal protective equipment for all abrasive blasting operations. Observe all applicable local, state and federal safety regulations in conjunction with airline filters and respiratory protection. Reference OSHA 29 CFR 1910.134.**
- 7. Do Not enter areas during abrasive blasting operations without breathing protection. All personnel in the vicinity of abrasive blasting operations should wear NIOSH approved air fed respirators, hoods or helmets.**
- 8. Do Not modify or alter any abrasive blaster, blast equipment or controls thereof without written consent from Axxiom Manufacturing, Inc.**
- 9. Do Not use bleeder type deadman valves on any Schmidt® abrasive blaster. The use of A-BEC, Clemco or a similar bleeder type deadman valve can cause unintentional start-up without warning, which can result in serious personal injury.**
- 10. Do Not sell, rent, or operate abrasive blasters without remote controls. OSHA regulations require remote controls on all blast machines. Failure to use remote controls can cause serious injury or death to the operator(s) or other personnel in the blasting area. Reference OSHA 29 CFR 1910.244(b).**
- 11. Do Not repair or replace any portion of Schmidt® equipment using components that are not Schmidt® original factory replacement parts. Use of replacement components that are not Schmidt® original factory replacement parts may result in equipment failure which can result in serious personal injury and in addition will void all warranties.**

Instructions for use of manual sections

This manual contains information needed to operate and maintain your abrasive blaster. Read this entire operations and maintenance manual before using your abrasive blaster. Pay close attention to the *Rules for Safer Operation* (Section 1.0), and the Dangers, Warnings, and Cautions identified.

The purpose of safety symbols and explanations are to alert you of the possible hazards and explain how to avoid them. The safety symbols and explanations do not by themselves eliminate any danger. However, following the instructions given and taking proper accident prevention measures will greatly lower the risk of injury to personnel. Below are the three hazard levels as used in this manual.



WHITE LETTERS with RED BACKGROUND

DANGER: Indicates an imminently hazardous situation that, if not avoided, will result in death or serious injury. This signal word is limited to the most extreme situations.



BLACK LETTERS with ORANGE BACKGROUND

WARNING: Indicates a potentially hazardous situation that, if not avoided, could result in death or serious injury.



BLACK LETTERS with YELLOW BACKGROUND

CAUTION: Indicates a potentially hazardous situation that, if not avoided, may result in minor or moderate injury. It may also be used to alert against unsafe practices that may cause property damage.

This manual contains terms that may be specific to the abrasive blast industry. Understanding these terms will help you understand the procedures and instructions given in this manual. Please familiarize yourself with the following terms and refer to them as needed while reading this manual.

Term	Definition
Pressure Vessel	A fabricated tank (or reservoir) that is part of the abrasive blaster which is filled with compressed air and abrasive. (Also referred to as “blast vessel” or “vessel”.)
Pressurize	To manually or automatically fill the abrasive blast vessel with compressed air.
Depressurize	To manually or automatically release all the compressed air from inside the abrasive blast vessel. (Also referred to as “blowdown”.)
Blowdown	To manually or automatically release all the compressed air from inside the abrasive blast vessel. (Also referred to as “depressurize”.)
Deadman	A manually operated valve or switch that allows remote starting and stopping of the blast operation. [Also referred to as “deadman valve” (pneumatic blast controls) or “deadman switch” (electric blast controls.)]
Popup	An air pressure operated valve that seals the abrasive inlet at the top of the pressure vessel. Its operation may be manual or automatic.
Abrasive	A granular substance used in an air blast operation that is the means for blasting the surface of an object. (Also referred to as abrasive blasting media.)
Silica	The crystalline chemical compound silicon dioxide (SiO ₂) which can be found in many natural abrasives and other substances. Breathing silica dust can cause respiratory diseases such as silicosis. (Also referred to as crystalline silica)

0.0 Warning Label Identification and Location

Listed below are the warning decals and the corresponding hazards related to this equipment. Refer to Figure 0.1 for images of the warning decals. Refer to Figure 0.2(a) and 0.2(b) for the locations of these warning decals on the Abrasive Blaster.

No.	Qty.	Part no.	Description	Hazard
1.	1	7031-002	Small “Schmidt”	Not Applicable
2.	1	7031-054	“Warning” Airborne particle and loud noise hazard.	Airborne particles and loud noise from blast nozzle and blowdown can cause injury and loss of hearing. Wear approved eye and ear protection. See Section 1.0 and 3.9.
3.	1	7031-007A	“Danger” Pressurized vessel.	Propelled objects will cause serious injury or death. Depressurize vessel prior to performing any maintenance. See Section 6.2.
4.	1	7031-057	“Warning” Read manual before using this machine.	Read and understand operator’s manual before using this machine. Failure to follow operating instructions could result in injury or damage to equipment. See Section 1.0.
5.	1	N/A	Welded “Warning” plate General hazard and advisory notes.	Steel “Warning” plate welded to pressure vessel which is a general list of required actions to take before and during the operation of this equipment. See Section 1.0.



1) 7031-002



2) 7031-054



3) 7031-007A



4) 7031-057

Figure 0.1 – Warning decal summary

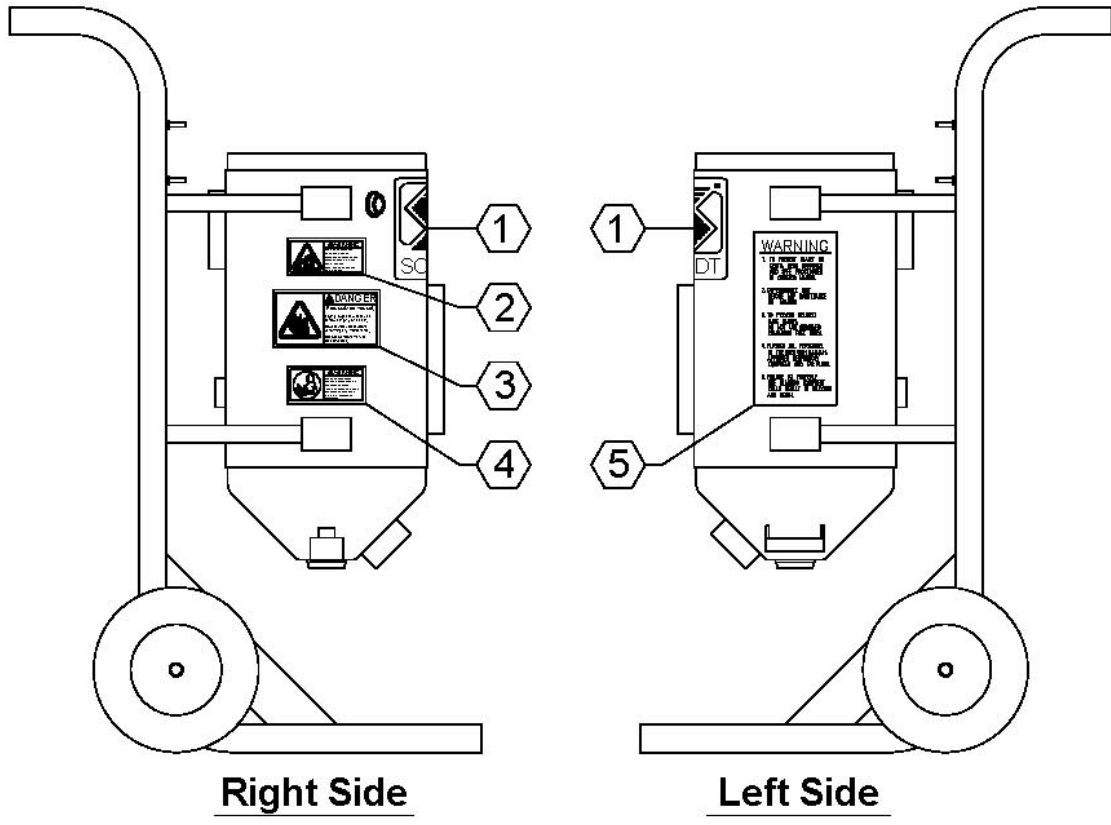

Figure 0.2(a) - Warning decal placement (M11)

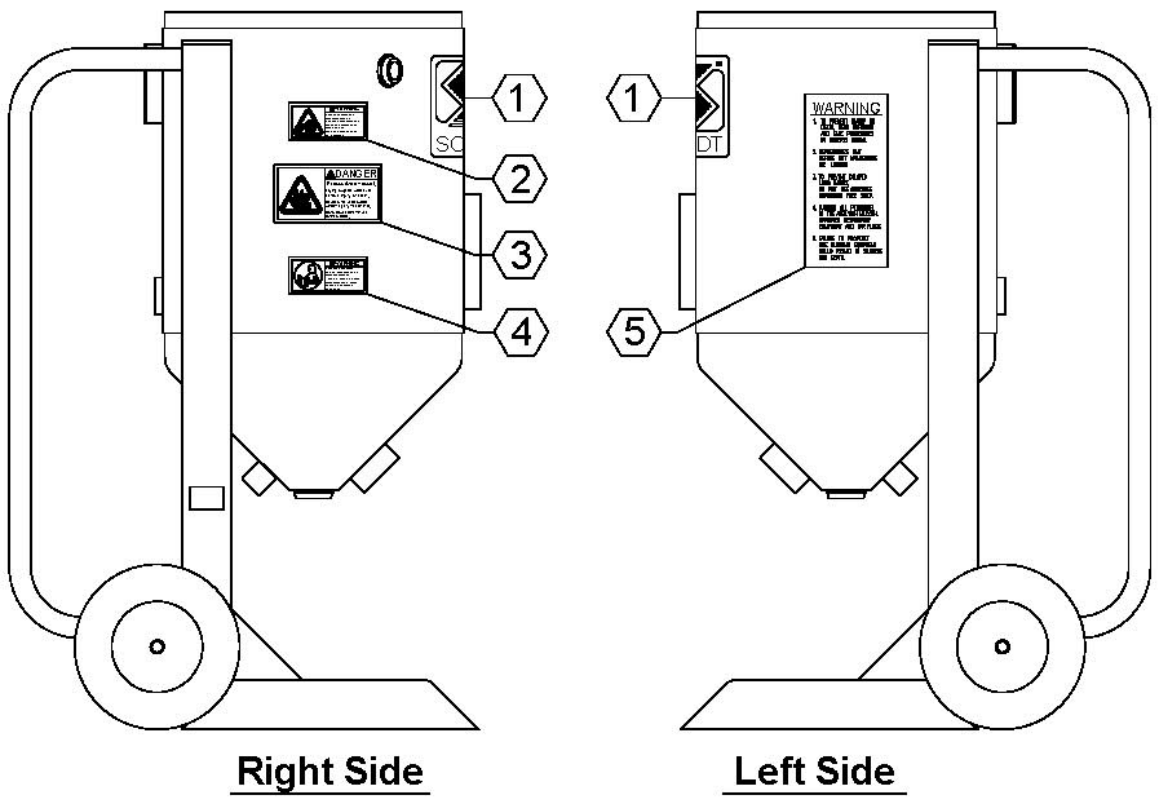

Figure 0.2(b) - Warning decal placement (M21 / M31)

THIS PAGE INTENTIONALLY BLANK

Table of Contents

Section	Page
0.0 Warning Decal Identification and Location	2
1.0 Rules for Safer Operation	6
2.0 Specifications and General Information	12
3.0 System Requirements and Personal Protective Equipment	16
4.0 Abrasive Blast System General Operation	19
5.0 Abrasive Blaster General Operation	20
6.0 Pre-operation Procedures	25
7.0 Operating Instructions	34
8.0 Maintenance and Inspection Instructions	37
9.0 Drawings and Parts Lists	43
10.0 Recommended Spare Parts Lists	60
11.0 Troubleshooting	61
12.0 Warranty and Reference Information	68
13.0 Blasting Data Tables	Back

1.0 Rules for Safer Operation

1.1. GENERAL RULE FOR SAFER OPERATION.

SCHMIDT® ABRASIVE BLASTERS HAVE BEEN DESIGNED TO BE SAFE WHEN USED IN THE PROPER MANNER. ALL ABRASIVE BLASTERS ARE POTENTIALLY DANGEROUS IF ALL SAFETY PRECAUTIONS ARE NOT RIGOROUSLY FOLLOWED. PROPER TRAINING IS REQUIRED BEFORE OPERATION. PROPER PROCEDURES MUST BE FOLLOWED. THE ABRASIVE BLASTER AND ALL COMPONENTS MUST BE PROPERLY MAINTAINED. FAILURE TO OPERATE, SERVICE AND MAINTAIN THE ABRASIVE BLASTER AS SET FORTH IN THIS MANUAL MAY CAUSE INJURY OR EVEN DEATH TO ANY PERSON USING, SERVICING OR IN THE VICINITY OF THE ABRASIVE BLASTER.

THIS MANUAL IDENTIFIES POTENTIAL HAZARDS BY DANGER, WARNING, AND CAUTION SYMBOLS. HOWEVER, ALL THE RULES, PROCEDURES AND RECOMMENDATIONS MUST BE FOLLOWED. FAILURE TO OPERATE PROPERLY IS VERY LIKELY TO PLACE PERSONS AND PROPERTY AT HIGH RISK OF DAMAGE, INJURY OR EVEN DEATH.



ABRASIVE BLASTERS AND THE ABRASIVE BLAST OPERATION ARE POTENTIALLY DANGEROUS IF ALL SAFETY PRECAUTIONS ARE NOT FOLLOWED. FAILURE TO OPERATE THE ABRASIVE BLASTER WITHOUT FOLLOWING ALL THE *RULES FOR SAFER OPERATION* MAY RESULT IN SERIOUS INJURY OR DEATH TO OPERATING PERSONNEL OR PERSONS IN THE OPERATING VICINITY.

1.2. KNOW YOUR EQUIPMENT.

Do Not operate this equipment in a manner other than its intended application (see Section 4.0). Do Not operate this equipment or any other Schmidt® equipment without following the *Rules for Safer Operation* and all the operating procedures and instructions. Learn the applications and limitations as well as the specific potential hazards related to this machine. Failure to do so could result in serious injury or death.

1.3. RECEIVE PROPER TRAINING.

Do Not operate this equipment unless you have received operational and maintenance training. Begin by thoroughly reading and understanding this operation and maintenance manual and all included information. Consult an authorized Schmidt distributor or Axxiom manufacturing, Inc.

1.4. PROTECT YOUR FEET.

Do Not operate this equipment without wearing OSHA approved foot protection. Observe all applicable local, state and federal regulations. See Section 3.9 and OSHA 29 CFR 1910.136.



Heavy objects can shift while being blasted and may fall on operators. Wear foot protection to prevent injury. See Section 3.9 and OSHA 29 CFR 1910.136.

1.5. PROTECT YOUR EYES.

Do Not operate this equipment without wearing OSHA approved safety glasses. Observe all applicable local, state and federal safety regulations. See Section 3.9 and OSHA 29 CFR 1910.133.



When filling the blast vessel and during the blast operation, abrasive can be blown in the face and eyes of operators. Wear OSHA approved safety glasses. See Section 3.9 and OSHA 29 CFR 1910.133.

1.6. PROTECT YOUR LUNGS.

Do Not operate this equipment without wearing OSHA approved respiratory protection. Abrasive blasting produces dust contaminated with toxic substances from the abrasive used, the coating being removed, and the object being blasted. This dust may contain Silica which can cause severe and permanent lung damage, cancer, and other serious diseases. Do Not breathe the dust. Do Not rely on your sight or smell to determine if dust is in the air. Silica and other toxic substances may be in the air without a visible dust cloud. If air-monitoring equipment for silica is not provided at the worksite, then all personnel **MUST** wear appropriate respiratory protection when using or servicing this equipment. Breathing air supplied to respirators must be of acceptable quality. Consult your employer and OSHA regarding the appropriate respiratory protection and breathing air quality. See Sections 3.8, 3.9, and OSHA 29 CFR 1910.134.



Abrasive blasting produces dust which may contain Silica and other toxic substances that can cause severe and permanent lung damage, cancer, and other serious diseases if inhaled. Wear OSHA approved respiratory protection. See Sections 3.8, 3.9, and OSHA 29 CFR 1910.134.

1.7. BREATHING AIR QUALITY.

Do Not use breathing air that does not meet OSHA Class D standards. Extreme caution must be taken when selecting a source of breathing air. Breathing air provided by an oil-lubricated air compressor can contain carbon monoxide and therefore requires the use of a carbon monoxide detector (See Section 3.9). Carbon monoxide can be in the compressed air produced by an oil-lubricated air compressor when it is operated at extremely high temperature; therefore a high temperature alarm is required to alert the operators when this condition exists. Reference OSHA 29 CFR 1910.134(i).

Extreme caution must be taken when connecting to factory air sources. Factories can have sources of compressed gases such as nitrogen which is fatal if used as a breathing air source. Verify that the air source is breathable air.



Breathing air must meet OSHA Class D standards. Use of breathing air sources that do not meet Class D standards can cause asphyxiation and result in death. Verify that all air sources are breathable quality and use a high-temperature alarm and a carbon monoxide monitor when required. See Sections 3.8, 3.9 and OSHA 29 CFR 1910.134(i).

Enclosed blast areas must be ventilated to reduce airborne dust to an acceptable level as required by OSHA 29 CFR 1910.1000.

1.8. PROTECT YOUR HEARING.

Do Not operate this equipment without wearing OSHA approved hearing protection. Observe all applicable local, state and federal safety regulations. See Section 3.9 and refer to OSHA 29 CFR 1910.95.



Loud noise is generated by the blast nozzle and the blowdown operation of this equipment. Wear OSHA approved hearing protection. See Section 3.9 and refer to OSHA 29 CFR 1910.95.

1.9. PROTECT YOUR PERSON

Abrasive blasting produces dust contaminated with toxic substances from the abrasive used, the coating being removed, and the object being blasted. All blast operators and other personnel involved in the blast operation or in the vicinity of the blast operation should wear protective clothing. The protective clothing should be disposable or washable work clothes that should be removed at the worksite so that contaminated dust is not transferred into automobiles or homes. See Section 3.9 and refer to OSHA 29 CFR 1910.94 and 1910.134.

1.10. ADHERE TO ALL REGULATIONS.

Do Not operate this equipment without observing all local, state, and federal safety regulations including, but not limited to, OSHA (Occupational Health and Safety Administration).

1.11. STAY ALERT.

Do Not operate this equipment when you are tired or fatigued. Use caution and common sense while operating and/or performing maintenance on this equipment.

1.12. DO NOT USE DRUGS, ALCOHOL, or MEDICATION.

Do Not operate this equipment while under the influence of drugs, alcohol, or any medication.

1.13. PROTECT BYSTANDERS.

Do Not allow blast equipment operators and other personnel to enter the vicinity of the blast operation without providing respiratory protective equipment that meets OSHA regulations. If dust concentration levels exceed the limitations set in OSHA 29 CFR 1910.1000 then respirators are required.

1.14. KEEP CHILDREN AND VISITORS AWAY.

Do Not allow children or other non-operating personnel to contact this equipment or the connecting hoses and cords. Keep children and non-operating personnel away from work area.

1.15. AVOID DANGEROUS ENVIRONMENTS.

Do Not operate this equipment without familiarizing yourself with the surrounding environment. The blast operation creates high level of noise which will prevent the operator from hearing other possible dangers (i.e. traffic or moving equipment). In such situations a stand-by watch person may be necessary to prevent injury to personnel.

1.16. AVOID DANGEROUS ENVIRONMENTS.

Do Not use this equipment in areas cluttered with debris. Debris in the work area can create tripping hazards which can cause the operator to loose control of the blast hose and result in injury to operating personnel. Keep work area clean and well lit. When working at an elevated location, pay attention to articles and persons below.

1.17. AVOID DANGEROUS ENVIRONMENTS.

Do Not operate this equipment in elevated areas without using fall protection equipment. Certain applications of this equipment may require the use of scaffolding. Use of scaffolding creates hazardous situations such as tripping and fall hazards which can result in serious injury or death to operating personnel. Consult OSHA 29 CFR 1910 Subpart D.

1.18. AVOID DANGEROUS ENVIRONMENTS.

Do Not blast objects that are not properly secured. The blast operation can cause the blasted object to shift or move. Extremely large objects to be blasted can create a crush hazard to operating personnel which can result in serious injury or death. Properly secure the object to be blasted.

1.19. AVOID DANGEROUS ENVIRONMENTS.

Do Not blast objects used to store flammable materials. The blast operation can cause sparks which can ignite fumes or residual flammable materials inside enclosed containers which can explode resulting in serious injury or death to operating personnel.

1.20. ELECTRICALLY GROUND EQUIPMENT.

Static electricity is generated by the abrasive flow through the blast hose. To prevent static electrical shock to operating personnel only use static dissipating blast hose and install a grounding strap on the abrasive blaster. See Section 5.8.

1.21. MAINTAIN VESSEL INTEGRITY.

Do Not operate this equipment with the pressure vessel damaged, or with any part of it worn or damaged. Do Not operate this equipment in a condition that may cause failure of the pressure vessel. See sections 1.21 through 1.31 below.



An abrasive blaster is a Pressurized Vessel. Alterations, damage, or misuse of the pressure vessel can result in rupturing. Damaged or incorrect components used on the abrasive blaster can result in rupturing. The compressed air inside a pressurized vessel contains a dangerously high level of energy which can propel objects and cause serious injury or death.

1.22. NEVER OPERATE OVER MAXIMUM WORKING PRESSURE.

Do Not operate this equipment above maximum allowable working pressure (MAWP) at maximum operating temperature (°F) shown on the ASME nameplate attached to the vessel. See Section 2.2 and 8.1.

1.23. INSTALL PRESSURE RELIEF DEVICE.

Do Not operate this equipment without a pressure relief device in place. The ASME Code requires that all vessels be equipped with pressure relief devices prior to installation. The pressure relief device must be set at the maximum allowable working pressure of the abrasive blaster. See the ASME nameplate attached to the vessel typically located above the handway. See Section 6.1.2 for information regarding the pressure relief valve.

1.24. NEVER OPERATE BEYOND ALLOWABLE TEMPERATURE RANGE.

Do Not operate this equipment above the maximum allowable temperature at the allowable pressure or below the minimum design metal temperature (MDMT) shown on the pressure vessel nameplate. The characteristics of the pressure vessel metal are weakened when the temperature is outside the operating range. Operating the pressure vessel outside of allowable temperature range can result in rupturing and cause serious injury or death.

1.25. ASME NAMEPLATE REQUIRED.

Do Not operate this equipment if the ASME pressure vessel nameplate is missing. Contact Axxiom Manufacturing, Inc. for technical support.

1.26. DO NOT MODIFY VESSEL.

Do Not modify or alter any abrasive blaster, blast equipment, or controls thereof without written consent from Axxiom Manufacturing, Inc. Do Not weld, grind, or sand the pressure vessel. *It will not be safe to operate.* Non-authorized modifications could lead to serious injury or death. Non-authorized modifications will void the warranty and the ASME certification.

1.27. DO NOT HAMMER ON VESSEL.

Do Not hammer on or strike any part of the pressure vessel. Hammering on the pressure vessel can create cracks and cause rupturing.

1.28. FIRE DAMAGE NOTICE.

Do Not operate if the pressure vessel has been damaged by fire. If damaged, take out of service immediately and have it inspected and/or repaired by a qualified facility. Contact Axxiom Manufacturing, Inc. for technical support.

1.29. INSPECT VESSEL REGULARLY.

Do Not operate this equipment with damage to the pressure vessel. *It is not safe.* Inspect outside and inside of the pressure vessel regularly for corrosion or damage (i.e. dents, gouges or bulges). If damaged, take out of service immediately and have it inspected and/or repaired by a qualified facility. Contact Axxiom Manufacturing, Inc. for technical support. See Section 8.0.

1.30. CHECK FOR LEAKS IN VESSEL.

Do Not operate this equipment if there is a leak in the pressure vessel. If leaking, take out of service immediately and have it inspected and/or repaired by a qualified facility. Contact Axxiom Manufacturing, Inc. for technical support.

1.31. NEVER MODIFY BLOWDOWN.

Do Not connect the blowdown on this equipment onto a common header with any other unit of any description, or any other source of compressed air, without first making sure a check valve is used between the header and this unit. Do Not install this equipment sharing piping with another unit of higher discharge pressure and capacity. A safety hazard could occur in the form of a back-flow condition.

1.32. DEPRESSURIZE VESSEL BEFORE PERFORMING MAINTENANCE.

Do Not remove, repair, or replace any item on this equipment while it is pressurized. Do Not attempt to perform maintenance or load abrasive while this equipment is pressurized or is even capable of being pressurized. This means the inlet ball valve should be closed and the air supply should be shut off or disconnected. Anytime the manual blowdown valve is closed it should be assumed that the abrasive blast vessel is pressurized.



An abrasive blaster is a Pressurized Vessel. The compressed air inside a pressurized vessel contains a dangerously high level of energy which can propel objects and cause serious injury or death. Depressurize vessel before performing any maintenance. See Section 6.2.

1.33. ALWAYS USE REMOTE CONTROLS.

Do Not sell, rent, or operate abrasive blasters without remote controls. OSHA regulations require remote controls on all abrasive blasters. All abrasive blasters must be equipped with automatic (deadman) type remote controls (either pneumatic or electric). Failure to use remote controls can cause serious injury or death to the operator(s) or other personnel in the blasting area. Reference OSHA 29 CFR 1910.244(b).

1.34. NEVER USE BLEEDER TYPE DEADMAN VALVES.

Do Not use bleeder type deadman valves on any Schmidt® abrasive blaster. The use of A-BEC, Clemco, or a similar bleeder type deadman valve can, without warning, cause unintentional start-up which can result in serious personal injury. A particle of dirt from the air hose can plug the bleed hole in the deadman valve and cause the blast outlet to turn on.

1.35. CHECK FOR DAMAGED PARTS.

Do Not use this equipment with damaged components. Damaged components can fail during operation and result in serious injury or death to operating personnel. Periodically check all valves, hoses, and fittings to see that they are in good condition. Repair any component that shows any sign of wear or leakage. See Section 8.0.

1.36. ALWAYS USE SAFETY PINS ON HOSE COUPLING CONNECTIONS.

Do Not use this equipment without hose coupling safety pins in place and hose whip checks installed on all air and blast hoses. All blast hose couplings and air hose couplings have pin holes that must be safety pinned to prevent accidental disconnections. Accidental hose disconnection can cause serious injury or death. See Section 5.10 and 8.7.

1.37. ALWAYS USE CORRECT REPLACEMENT PARTS AND ACCESSORIES.

Do Not use replacement parts or accessories that are not rated for pressures equal to or higher than your abrasive blaster's operating pressure. Improper hoses and/or fittings used on, or connected to your abrasive blaster can rupture and cause serious injury or death.

Do Not use replacement parts that are not Schmidt original factory replacement parts. Non-original parts may not fit properly and can cause equipment damage and/or failure which can result in serious injury to operating personnel. Consult Axxiom Manufacturing, Inc.



Use of replacement components that are not Schmidt original factory replacement parts may result in equipment failure which can result in serious injury to operating personnel.

1.38. ALWAYS USE CORRECT PRESSURE RATED ACCESSORIES.

Do Not use air reservoirs or moisture separator tanks that are not rated for use in compressed air applications. Air reservoirs and moisture separator tanks larger than 6 inches inside diameter must have an ASME code stamp.



An air reservoir or moisture separator tank is a Pressurized Vessel. The compressed air inside a pressurized vessel contains a dangerously high level of energy which can explode propelling objects and result in serious injury or death to operating personnel. Air reservoir and moisture separator tanks must be ASME coded tanks.

1.39. NEVER AIM BLAST NOZZLE TOWARDS ANY PERSON.

Do Not aim the blast nozzle towards yourself or any person. System malfunction can cause accidental start up and result in injury to personnel.

1.40. NEVER USE ABRASIVE NOT INTENDED FOR BLAST EQUIPMENT.

Do Not use abrasive blast media containing free silica. Silica can cause silicosis or other related respiratory damage. Verify that the abrasive is intended for use in blasting equipment. Personal protective equipment, including airline filters and respirators, must be used for all abrasive blasting operations. Observe all applicable local, state and federal safety regulations. See Section 3.9 and reference OSHA 29 CFR 1910.134.

1.41. CHECK ABRASIVE FOR DEBRIS.

Do Not use blast abrasive that contains trash or other debris. Trash or debris can create a blockage and cause equipment malfunction. Screen recycled abrasive to remove trash.

1.42. STOP OPERATION IMMEDIATELY IF ANY ABNORMALITY IS DETECTED.

Do Not operate this equipment if anything abnormal is seen during operation. Stop operation immediately for inspection.

1.43. DO NOT OVERLOAD THE LIFT EYES.

Do Not load the lifting eyes above the rated capacity. Do Not lift the blast vessel by any point other than the lifting eyes. See Section 2.6.

1.44. MAINTAIN WARNING DECALS.

Do Not remove, cover, obstruct, or paint over any warnings, cautions, or instructional material attached. Warning decals must be installed, maintained, and located to be visible and with enough light for legibility. See Section 0.0 and 8.12.

1.45. SAVE THIS OPERATION AND MAINTENANCE MANUAL.

Refer to this operation and maintenance manual as needed as well as any additional information included from other manufacturers. Never permit anyone to operate this equipment without having him/her first read this manual and receive proper training. Make this manual readily available to all operating and maintenance personnel. If the manual becomes lost or illegible replace it immediately. This operation and maintenance manual should be read periodically to maintain the highest skill level; it may prevent a serious accident.

1.46. SAFETY REFERENCES

See Section 12.4 for safety information sources and contact information. Use these sources to obtain additional information regarding all aspects of blast operation safety.

2.0 Specifications and General Information

2.1 Notes To Distributors and Owners

- 2.1.1. Verify that the deadman, twinline (or cords), and the operation and maintenance manual are included with the abrasive blaster when it is received. Verify that the deadman, twinline (or cords), and the operation and maintenance manual are included with the abrasive blaster when it is delivered to the purchaser.
- 2.1.2. This equipment is intended for knowledgeable and experienced users. No person or persons should be allowed to operate this equipment without first receiving proper training in abrasive blasting operation and use of this equipment.
- 2.1.3. Immediately notify Axxiom Manufacturing, Inc. of any instances of use of this equipment in any manner other than the intended application. See Section 4.0.
- 2.1.4. Only qualified personnel should load and unload this equipment for shipping. Slings or other lifting devices must only be attached to the designated lifting points. See the lifting diagrams shown in Section 2.6.
- 2.1.5. For further information contact:
 - Axxiom Manufacturing, Inc.
 - 11927 South Highway 6
 - Fresno, Texas 77545
 - Phone: 1-800-231-2085
 - Fax: 1-281-431-1717
 - Website: www.axxiommfg.com

2.2 M Series Abrasive Blaster Operational Specifications

Maximum Working Pressure	150 psig @ 250°F (see ASME nameplate)
Minimum Metal Temperature	-20°F @ 150 psig (see ASME nameplate)
Air Consumption	See Section 13.0 table 1
Abrasive Consumption	See Section 13.0 table 2
Blast Hose Size	See Section 13.0 table 3
Electrical requirements	See Section 3.6
Abrasive Capacity	M11: 1.0 cu ft
	M21: 2.0 cu ft
	M31: 3.0 cu ft

2.3 Important Reference Numbers

Fill in the M Series Abrasive Blaster model number and serial number in the blank spaces below. These will be used for reference whenever service or maintenance is required.

M Series Abrasive Blaster Model Number _____

M Series Abrasive Blaster Serial Number _____

2.4 Vessel Information

- 2.4.1. All pressure vessels used in Schmidt Abrasive Blasters are manufactured in strict accordance with the provisions of the ASME Code Section VIII, Div. 1.
- 2.4.2. In order to maintain the high level of quality and quality control used in the manufacture of this vessel, it is required that any and all welded repairs to this vessel be performed by a reputable shop holding a National Board “R” Stamp and/or an ASME “U” stamp, depending on state or city law. Welding on the vessel performed by welders not properly qualified per the ASME Code voids the ASME/NB integrity of that particular vessel.

2.5 Notes

2.6 M Series Abrasive Blaster Lifting Diagrams

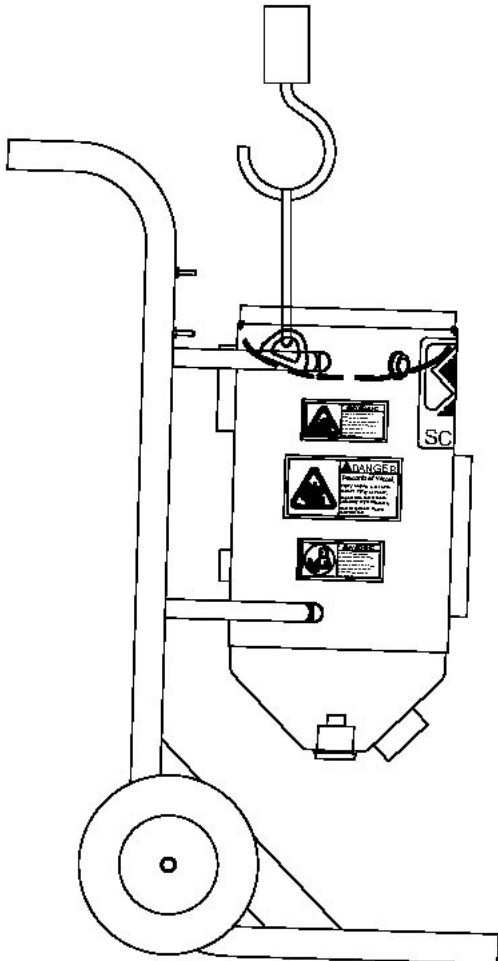

M SERIES MODEL M11

LIFT LUG FOR LIFTING
(MAXIMUM LOAD 473 LBS.)
EMPTY WEIGHT = 186 LBS.

***CRITICAL: THIS DRAWING IS FOR REFERENCE ONLY. ALL LIFTING MUST BE PERFORMED BY QUALIFIED PERSONNEL IN CONJUNCTION WITH ALL APPLICABLE SAFETY CODES.**

Figure 2.1 – M11 Lifting Diagram

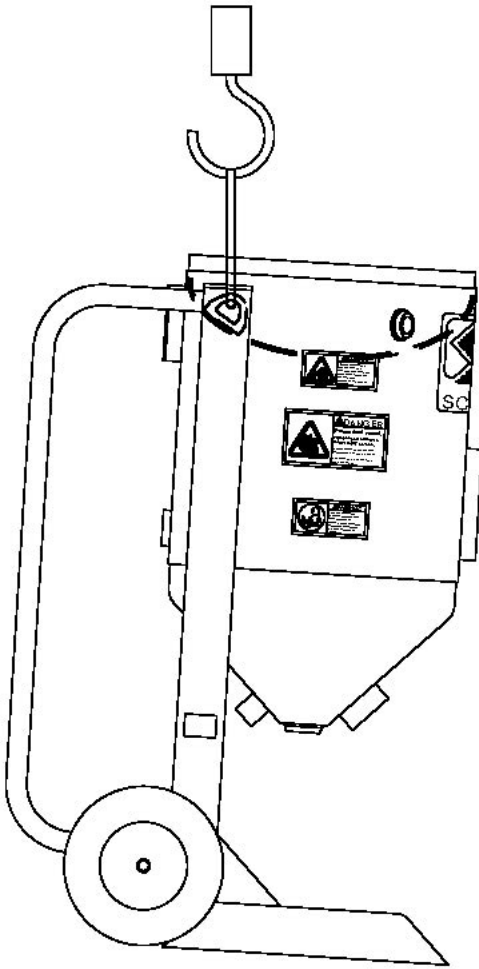

M SERIES MODEL M21/M31

LIFT LUG FOR LIFTING
(MAXIMUM LOAD 550 LBS.)
EMPTY WEIGHT = 294 LBS.

***CRITICAL: THIS DRAWING IS FOR REFERENCE ONLY. ALL LIFTING MUST BE PERFORMED BY QUALIFIED PERSONNEL IN CONJUNCTION WITH ALL APPLICABLE SAFETY CODES.**

Figure 2.2 – M21/M31 Lifting Diagram

2.7 M Series Abrasive Blaster Dimensional Specifications

Model No.	Part No.	HEIGHT* in (mm)	WIDTH in (mm)	LENGTH in (mm)	WEIGHT lbs (kg)
M 11	8720-011	48 (1219)	22 (559)	33 (838)	186 (84)
M 21	8720-021	50 (1270)	24 (610)	33 (838)	294 (133)
M 31	8720-031	56 (1422)	24 (610)	33 (838)	307 (139)

*Heights include lid and screen

3.0 System Requirements and Personnel Protective Equipment

3.1 Compressed Air Requirements

Blast nozzle

The primary air consumption is by the blast nozzle. This usage can vary greatly depending upon the number of blast outlets, nozzle size of each outlet, and the blast pressure. See Table 1 in Section 13.0 for air consumption by nozzle size at various pressures.

3.2 Air compressor size

The air compressor must be large enough to supply:

- i. The sum of blast air requirements for each nozzle at the highest pressure that will be used (see Section 13.0, Table 1).
- ii. The 12 CFM breathing air supplied to each blast operator respirator. **NOTE:** Reference OSHA regulations regarding requirements for breathing air, especially when an oil-lubricated air compressor is used.

3.3 Blast System Air Supply Line

The air supply hose and fittings must be rated at a minimum of 150 psi operating pressure. The air supply hose from the air compressor to the blast unit should be at least the same diameter as the air inlet piping (see Section 9.0). This size hose will be large enough to supply the required airflow to operate the blast unit controls and each blast nozzle. **Note:** If other equipment will be using the same source of air as the abrasive blaster, install a check valve at the air inlet. This will prevent back flow, which would carry abrasive into the control system.

3.4 Blast System Air Pressure

The maximum operating pressure for the blast unit is stamped on the ASME nameplate attached to the vessel. This unit may or may not be equipped with a system air pressure regulator, but if one is to be field installed it is important that the air supply to the control system be a minimum of 55 psig. If an air pressure regulator is installed the air supply to the blast controls must be taken upstream of the regulator. See Figure 5.3 and 5.4.

3.5 Blast System Air Quality

Moisture condensation in a blast system causes abrasive flow problems. Condensation occurs when the hot vapor-filled compressed air cools as it reaches the abrasive blaster. Therefore, a moisture removal device is recommended (i.e. coalescing moisture separator, air-cooled aftercooler or deliquescent dryer). Contact a local authorized Schmidt® distributor or Axxiom Manufacturing, Inc. to locate one near you.

3.6 Electrical Requirements

On units equipped with electric blast controls the supply voltage is 12Vdc or 24Vac. The maximum power required is:

1-outlet without abrasive cut-off:	7 watts
1-outlet with abrasive cut-off:	14 watts

3.7 Abrasive Selection

Abrasive selection is likely the most difficult decision related to the blast operation. Choice of abrasive is based on factors such as blast application type, desired finish and coating requirements, characteristics of object to be blasted, cost and ability to recycle, available equipment, safety, and environmental constraints.

There are many abrasives available that are either natural, manufactured, or processing by-products. Abrasives are available in varying sizes, shapes, and hardness. These characteristics determine the resulting effect on the surface to be blasted and limitations of its use. The effects on the blasted surface are measured by its degree of cleanliness and the surface profile. Standards and required levels of these measurements are established by organizations such as Steel Structures Painting Council (SSPC), National Association of Corrosion Engineers (NACE) and coating manufacturers. See Section 12.5 for contact information of these organizations. Use these sources to obtain information regarding all aspects of surface preparation and abrasive selection guidelines.

The M Series abrasive blaster is designed for high production open abrasive blasting with a wide range of abrasives. It is the responsibility of the employer and operators to select the proper abrasive. It is the responsibility of the employer to make certain that the abrasive selected is safe to use for abrasive blasting.

CRITICAL: Always obtain the Material Safety Data Sheet (MSDS) for the abrasive to be used. The MSDS provides the chemical makeup of the abrasive. Do Not use abrasives containing toxic materials. Refer to OSHA 29 CFR for acceptable limits of various toxic substances and additional measures to be taken to protect operating personnel. Always use abrasives containing less than 1% of crystalline silica. Always use a NIOSH approved respirator when handling, loading and cleaning up abrasives. Organic substances which are combustible may only be used in automated blast systems with ventilation that meets OSHA 29 CFR 1910.94.

3.8 Breathing Air Quality

All blast operators must be supplied with and required to use NIOSH approved air-fed respirators. Breathing air supplied to these respirators must meet Grade D air quality standards as specified by OSHA 29 CFR 1910.134(i) and the Compressed Gas Association Specifications ANSI/CGA G-7.1. Consult these specifications when selecting a source of breathing air.

Breathing air must be clean, dry, contaminant-free, and provided at a pressure and volume specified by NIOSH. Use NIOSH approved air filters on all sources of breathing air. See Section 3.9.

DANGER

Breathing air filters do not remove carbon monoxide or any other toxic gases. Use a carbon monoxide monitor to detect unacceptable levels. Consult OSHA 29 CFR 1910.134(i).

Many sources of breathing air are available such as air cylinders, free-air pumps, oil-less air compressors, and oil lubricated air compressors. The most commonly used is the same air compressor that is used for the blast air which most often is oil lubricated. Breathing air provided by an oil-lubricated air compressor can contain carbon monoxide and therefore requires the use of a carbon monoxide detector (See Section 3.9). Carbon monoxide can be in the compressed air produced by an oil-lubricated air compressor when it is operated at extremely high temperature; therefore a high temperature alarm is required to alert the operators when this condition exists.

DANGER

Oil lubricated air compressors can produce carbon monoxide. Carbon monoxide can cause asphyxiation and result in death. Use a high-temperature alarm and a carbon monoxide monitor when an oil lubricated air compressor is used to supply breathing air. Consult OSHA 29 CFR 1910.134(i).

3.9 Personal Protective Equipment (PPE)

Abrasive blasting has many hazards that may cause injuries to operators. To protect operators from injury each must be supplied with and required to use Personal Protective Equipment. The Occupational Health and Safety Administration (OSHA) requires the employer to assess the workplace to determine what PPE is necessary and supplied to each operator (Reference 29 CFR 1910 Subpart I). OSHA requires that this equipment meet or be equivalent to standards developed by the American National Standards Institute (ANSI). Figure 3.9 below identifies the minimum personal protective equipment required for each abrasive blast operator. Also identified are the OSHA references for each and the ANSI standard each PPE item must meet. All PPE clothing and equipment should be selected for safe design and quality of construction. Select each for proper fit and for comfort which will encourage operator use.



Safety Glasses

Reference OSHA 29 CFR 1910.133
Must meet ANSI Z87.1 - 1989



Safety Boots

Reference OSHA 29 CFR 1910.136
Must meet ANSI Z41.1 - 1991



Ear Plugs

Reference OSHA 29 CFR 1926.101
Must meet ANSI S3.19
(Also see OSHA 29 CFR 1910.95)

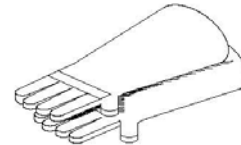

Gloves

Reference OSHA 29 CFR 1910.138
No Applicable ANSI Standard

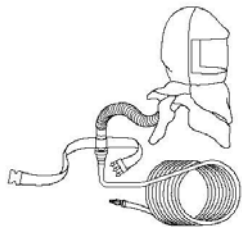

Respirator

Reference OSHA 29 CFR 1910.134
Must be NIOSH approved



Protective Clothing

Reference OSHA 29 CFR 1910.138
No Applicable ANSI Standard

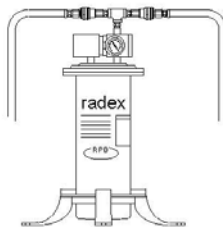

Airline Filter

Reference OSHA 29 CFR 1910.134
Must be NIOSH approved

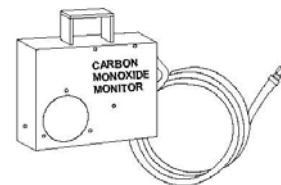

Carbon Monoxide Monitor

Figure 3.1 - Personal Protective Equipment

4.0 Abrasive Blast System General Operation

The function of the Schmidt® abrasive blaster is to provide a mixture of dry abrasive and compressed air to a blast nozzle. The abrasive blast stream through the blast nozzle is used for removing rust, paint, or other unwanted surface defects. After abrasive blasting, the surface is ready for new paint or coating.

The M Series Abrasive Blaster is one of a group of components used in an abrasive blasting job. The typical components are an air compressor, moisture removal device, an abrasive blaster, blast hose, a blast nozzle, operator personal protective equipment, and blast abrasive. See Figure 4.1.

The blast abrasive is loaded into the abrasive blaster through a top fill port. All the compressed air must be removed from inside the abrasive blaster before it can be filled with abrasive. The abrasive can be bag loaded, or loaded from a Schmidt storage hopper. To begin blasting the fill port is closed and the abrasive blaster is filled with compressed air from the air compressor. Since moisture creates problems in the blast operation, it is common for the compressed air to be fed through a moisture removal device, such as a Schmidt Air Prep System. The air pressure in the abrasive blast vessel is equal to the air pressure in the blast hose where it connects at the Thompson Valve. This equal pressure is needed to allow the blast abrasive to flow downward by gravity. The abrasive flow is controlled by the Thompson Valve at the bottom of the blaster. At this point, the blast abrasive flows into the blast air stream and through the blast hose. The speed of blast air and abrasive mixture is greatly increased by the blast nozzle onto the work surface. The high speed of the air and abrasive is what gives it the energy to blast rust and paint off of surfaces. The abrasive blast stream and the dust it creates is harmful, therefore all blast operators must use personal protective equipment during the blast operation.

All the components required for the blast operation (except for the air compressor) are available from Axxiom Manufacturing, Inc. Call Axxiom to locate a distributor.

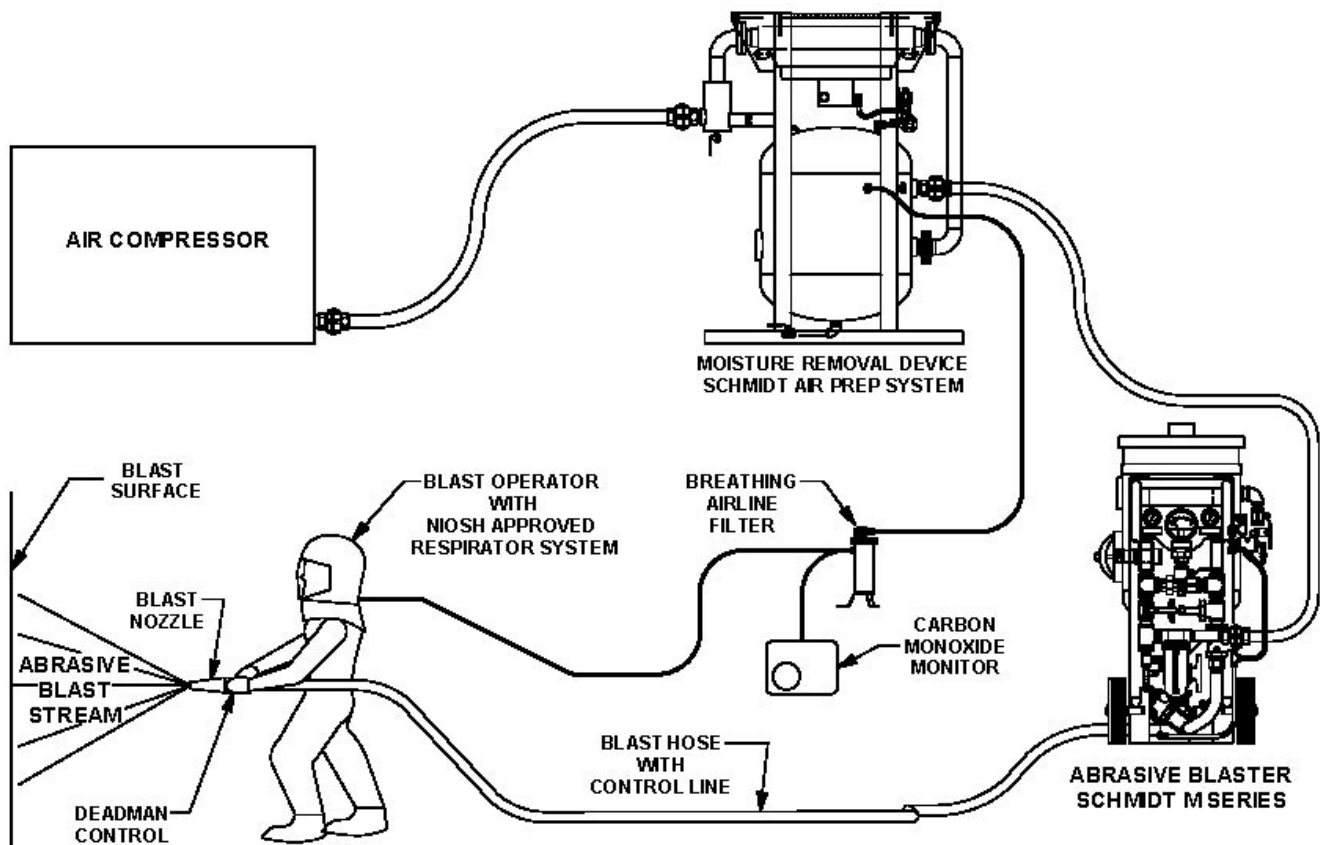

Figure 4.1 – Typical Abrasive Blast System

5.0 M Series Abrasive Blaster General Operation

See Figure 5.1 below to help understand the general operation. Do not attempt to operate the M Series abrasive blaster before reading all sections of this manual and following all setup procedures. See Sections 5.1 through 5.18 and Section 6.0.

The M Series Abrasive Blaster is designed to be used with a broader range of blasting abrasives than a typical blaster. The M Series Blaster has features for blasting at high or low pressure and has features for improved abrasive flow and flow control.

The M Series blaster (#12) will pressurize when the blowdown ball valve (#1) is closed and the air inlet ball valve (#5) is opened. The compressed air enters the moisture separator (#7) and then is branched off to the blast outlet and pressurizes the abrasive blast vessel. The air flow into the blast vessel internal piping will push the popup (#41) against the gasket (#40). This will seal the abrasive inlet which allows the air flow to fill and pressurize the abrasive blast vessel (#12).

Blasting begins when the deadman lever (#26) is pressed down which will pneumatically or electrically open the blast control valve (#13). When the control valve opens it sends an air signal that opens both the automatic air valve (#17) and the Thompson Valve® (#11). Compressed air will pressurize the blast hose (#25) when the automatic air valve (#17) is opened. At the same time the Thompson Valve (#11) will open and abrasive falls through and into the blast air stream. The abrasive flow can be increased or decreased by turning the knob on top of the Thompson Valve.

Blasting stops when the deadman lever (#26) is released. This will close the blast control valve (#13) and vent the air signal to the automatic air valve (#17) and the Thompson Valve (#11). When the signal air vents, both valves spring return into their “normally closed” position. The M Series Abrasive Blaster (#12) remains pressurized when the automatic air valve and Thompson Valve are turned off.

The M Series Abrasive Blaster (#12) is depressurized by closing the air inlet ball valve (#5) and then opening the blowdown ball valve (#1) to completely vent the compressed air.

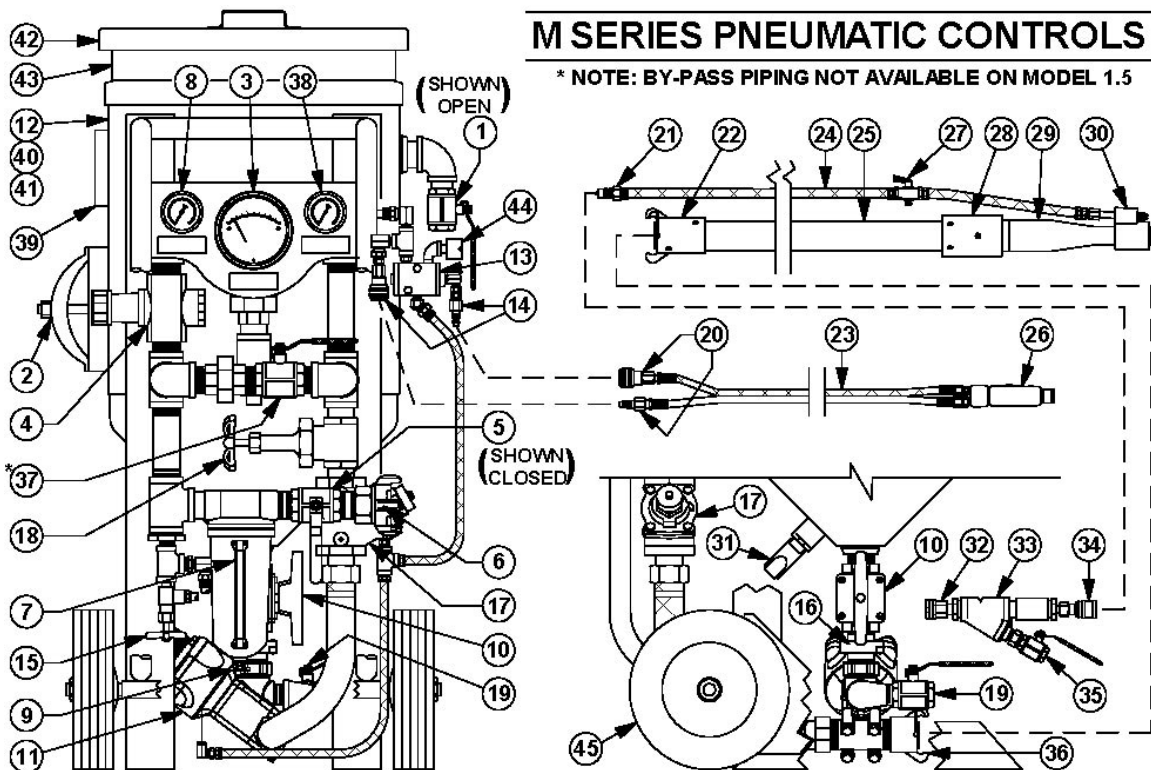

Figure 5.1 – Typical M Series Abrasive Blaster

5.1 Air Supply Connection

Air is supplied to the abrasive blaster through a hose connection at the air inlet crowfoot (#6). The air supply hose connected to the abrasive blaster must be the same diameter as the air supply piping. See the drawings and parts lists in Section 9.0 and refer to Sections 3.3 and 5.18.

5.2 Air Inlet Ball Valve (pressurize)

The air inlet ball valve (#5) is used to turn on and turn off the air flow to the abrasive blaster. When the inlet ball valve is opened air flow will automatically close the popup valve at the abrasive inlet and pressurize the M Series abrasive blaster (see Figure 5.2). The blowdown ball valve (#1) must be closed before opening the air inlet ball valve.

⚠ DANGER

The M Series Abrasive blaster is a pressurized vessel. Propelled objects will cause serious injury or death. Read and follow all pre-operation and operating procedures prior to pressurizing the abrasive blaster. See Section 6.0 and 7.0.

5.3 Blowdown Ball Valve (depressurize)

The blowdown ball valve (#1) is used to release all the compressed air (depressurize) from inside the abrasive blaster. The abrasive blaster must be depressurized for filling with abrasive or for performing any maintenance. The air inlet ball valve (#5) must be closed before depressurizing the abrasive blaster.

⚠ WARNING

Airborne particles and loud noise hazards from blowdown exhaust air can cause serious injury and loss of hearing. Wear approved eye and ear protection. Stay clear of blowdown air path. DO NOT place hands or other body parts in the blowdown air path. Make sure no personnel are in the blowdown air path.

5.4 Popup Valve (abrasive inlet)

The blaster is filled with abrasive through the opening at the top of the pressure vessel. This opening is automatically sealed by the popup head (#41) when the blaster is pressurized. The air flow into the internal piping pushes the popup up against the gasket (#40). See Section 5.2.

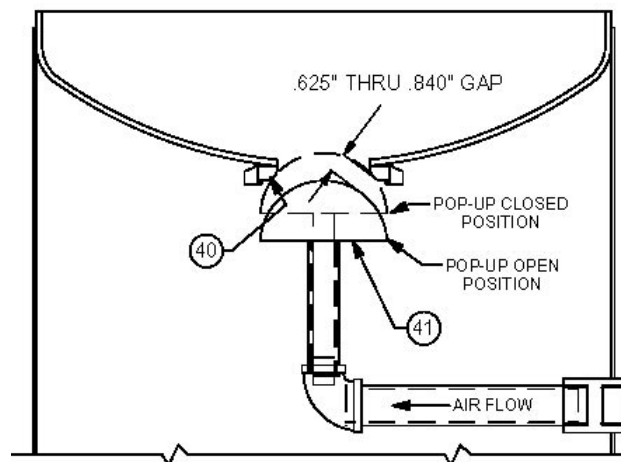

Figure 5.2 – Popup Assembly

⚠ WARNING

Pinch point hazard. Vessel pressurization will close the popup. Keep fingers clear of the popup opening. Disconnect air supply prior to performing popup maintenance.

5.5 Air Supply

When the air inlet ball valve (#5) is opened the air flow passes through the air filter (#7) which removes moisture, oil and dirt particles. The water that is removed by the filter can be drained by opening the petcock valve (#9) located at the bottom of the filter. This valve should be left slightly opened anytime the blaster is in operation. This allows water to be drained as it is filtered from the blast air. After passing the filter the air flow branches off to supply the accessory controls, the regulated tank/blast air pressure piping (#4) and the bypass piping (#37). The regulated air piping and the bypass air piping are the two ways to pressurize the abrasive blast vessel and supply the blast air line.

5.6 Regulated Tank/Blast Pressure Control

To blast objects that are fragile it is necessary to reduce the blast air pressure. The tank and blast air pressure can both be adjusted by the pressure regulator (#4). The pressure is adjusted by turning the knob on top of the regulator valve body (CW-increases pressure, CCW-decreases pressure). The tank/blast pressure is shown by the pressure gauge (#8). The bypass ball valve (#37) must be closed to use the regulated air pressure piping. **Note:** The air pressure regulator (#4) is non-relieving which means that when the pressure is decreased by turning the knob the tank air pressure *will not* reduce on the pressure gauge. The pressure will reduce only while blasting. The non-relieving feature prevents air from flowing backwards from the tank to the regulator which would carry abrasive.

5.7 Full Pressure Bypass

The bypass piping is a detour of the regulated air supply to provide full line pressure to the tank and blast air line. This allows blasting at full pressure for tougher applications without changing the setting of the air pressure regulator (#4). Open ball valve (#37) to bypass the pressure regulator and allow blasting at full air pressure. Then close the ball valve (#37) to go back to using the regulated pressure control. **Note:** Bypass piping is not available on model M11.

5.8 Gate Valve (Differential Pressure Control)

When the automatic air valve opens inlet air supply flows through the gate valve (#18) to the Thompson valve® (#11) where it mixes with abrasive for blasting. The purpose of the gate valve is to reduce the blast air pressure slightly below the tank pressure. This adjustment is called “*differential pressure*” (blast pressure lower than tank pressure). Differential pressure is used when blasting with fine grain abrasives which do not flow well out of the blast vessel and through the Thompson Valve. Turn the gate valve handle clockwise to close the valve and decrease blast pressure. This will increase the differential pressure which will increase abrasive flow. Turn the handle counter-clockwise to decrease differential pressure which will decrease abrasive flow. This differential pressure adjustment must be made while blasting so that the effects are visible. The blast pressure is indicated by the pressure gauge (#38). Differential pressure can be viewed on the differential pressure gauge (#3).

5.9 Automatic Air Valve

The automatic air valve (#17) is a normally closed valve that opens to supply blast air to the blast hose and blast nozzle (#25 & #29). The automatic air valve opens when it receives air to its signal port. This happens when the deadman lever (#26) is pressed down which opens the blast control valve (#13) sending an air signal to the automatic air valve. When the deadman lever is released the air signal from the blast control valve vents and automatic air valve spring closes to stop blast air to the blast hose and nozzle. See Section 9.7.

5.10 Thompson Valve®

The Thompson Valve (#11) is a dual-purpose valve. First, it is a normally closed valve that opens to supply abrasive into the blast air stream. The Thompson Valve opens when it receives air to its signal port (See Section 9.4 and 9.5). This happens when the deadman lever (#26) is pressed down which opens the blast control valve (#13) sending an air signal to the Thompson Valve. When the deadman lever is released the air signal from the blast control valve vents and Thompson Valve spring closes to stop abrasive flow to the blast hose and nozzle (#25 & #29).

Secondly, the Thompson Valve® (#11) is an abrasive metering valve. When the Thompson Valve is open the abrasive flow is metered (controlled) by an adjustable orifice. The amount this orifice opens is controlled by turning the knob at the top of the Thompson Valve. The knob sets the stopping point of the plunger (See Section 9.4 & 9.5). Turn the knob clockwise to reduce the orifice size which decreases abrasive flow. Turning the knob counter-clockwise increases the orifice size which will increase the abrasive flow to the blast nozzle (#29). The Thompson Valve spring retainer has lines on the side to use as reference points to the amount that the orifice is open. Adjustments to the abrasive flow should be made by turning the knob a little at a time. Test the adjustment by starting the blast for a short period to determine if further adjustment is needed.

The Thompson Valve II has a built in cleanout port where a ball valve can be installed (see Section 9.5). This ball valve can be used to purge (blow out) trash that blocks abrasive flow. This is done by closing the abrasive shutoff valve (#10), opening the clean out valve (#19), and then pressing down the deadman lever (#26). The blast air flows through the Thompson Valve and purges any trash through the clean out valve. **Note:** If the abrasive blaster is equipped with the abrasive cut-off feature set the cut-off valve (or switch) to the on-position for the Thompson Valve® to open for purging. See Sections 9.3(a) and 9.3(b).



Airborne particles and loud noise hazards from purge air can cause serious injury and loss of hearing. Wear approved eye and ear protection. Stay clear of purge air path. **DO NOT** place hands or other body parts in the purge air path. Make sure no personnel are in the purge air path.

5.11 Abrasive shutoff Valve

The abrasive shutoff valve (#10) allows the operator to remove the Thompson Valve from the blast vessel without emptying the abrasive. Turn the abrasive shutoff valve handle to the horizontal position will block abrasive flow from the blast vessel (#12) into the Thompson Valve. Then the spring clamp (#16) is removed to separate the Thompson Valve from blast vessel.



The M Series abrasive blaster is a Pressurized Vessel. Propelled objects will cause serious injury or death. Depressurize vessel before performing any maintenance. See Section 6.2.

5.12 Deadman Valve/Switch

The Deadman valve/switch is part of a system that controls the blast operation. The deadman valve/switch (#26) allows the operator to remotely start and stop the blast operation. The Deadman is mounted at the end of the blast hose assembly (#25) close to the blast nozzle (#29) to give the operator easy control of the blast operation.

The Deadman is either a pneumatic valve or an electric switch depending on the type of abrasive blaster control system. When the deadman lever is pressed down it sends either a pneumatic or electric signal to the blast control valve (#13). The control valve opens and sends an air signal to the automatic air valve (#17) and the Thompson Valve (#11). See Sections 9.1, 9.2 and 9.3.

5.12.1. Pneumatic Deadman System: When the pneumatic deadman lever is pressed down air supply from the orange hose of the twinline hose (#23) flows into the black hose. Air flows through the black hose to the signal port of the control valve (#13) causing it to open and send air signals to the auto air valve (#17) and the Thompson Valve® (#11). When the deadman lever is released the air signal is cut off and the remaining air vents from the breather (#44). See Figure 5.3 and the drawings in Section 9.1.

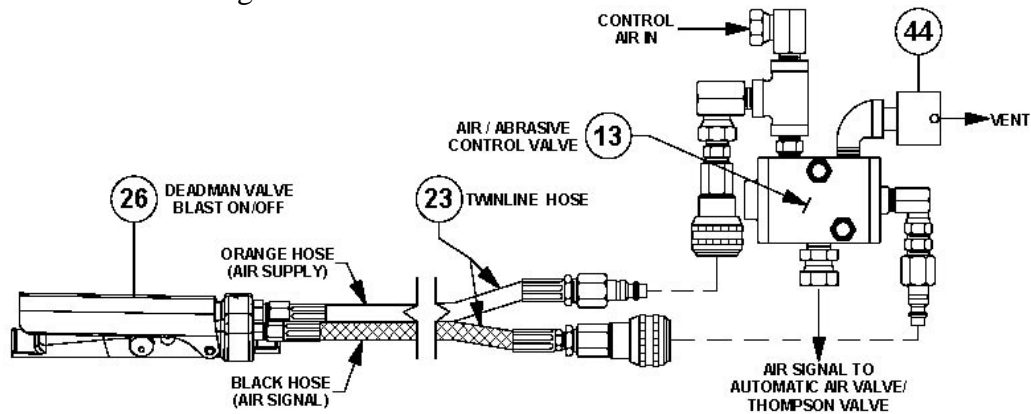

Figure 5.3 – Pneumatic Blast Control System

5.12.2. Electric Deadman System: When the electric deadman lever is pressed down it closes the electric circuit and supplies electric current to the control valve (#13). The control valve opens and sends air signals to the auto air valve (#17) and the Thompson Valve® (#11). When the deadman lever is released the electric circuit is cut off closing the control valve. The signal air vents from the breather (#44). See Figure 5.4 and the drawings in Section 9.2.

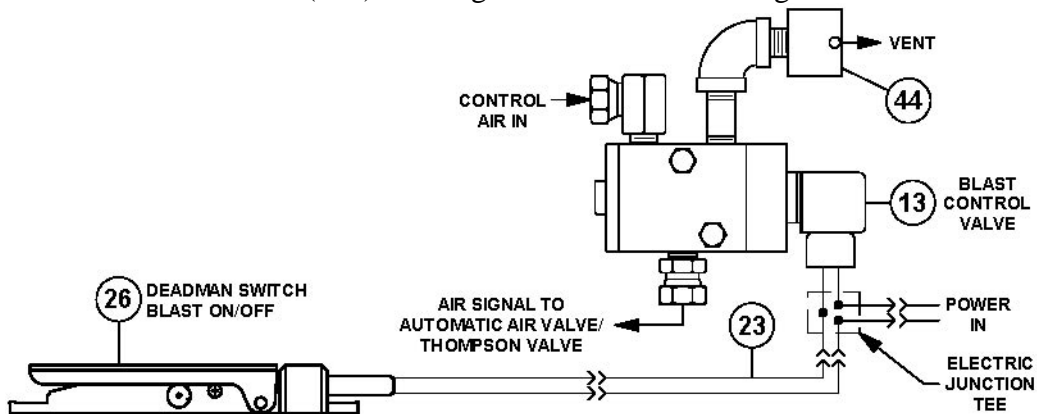

Figure 5.4 – Electric Blast Control System

5.13 Abrasive Cut-Off

An optional feature of a blaster is an abrasive cut-off. The purpose of the abrasive cut-off is to allow blasting air without abrasive. This is useful for blowing off abrasive from the blasted item. To blast with air only set the abrasive cut-off valve (or switch) to the off-position then press down the deadman lever (#26). This will send a control signal to the automatic air valve only, therefore only blast air will exit the blast nozzle (#29). For the abrasive cut-off to work a second control valve is needed that provides a signal to the Thompson Valve® separate of the air signal to the automatic air valve. Refer to the drawings in Section 9.3.

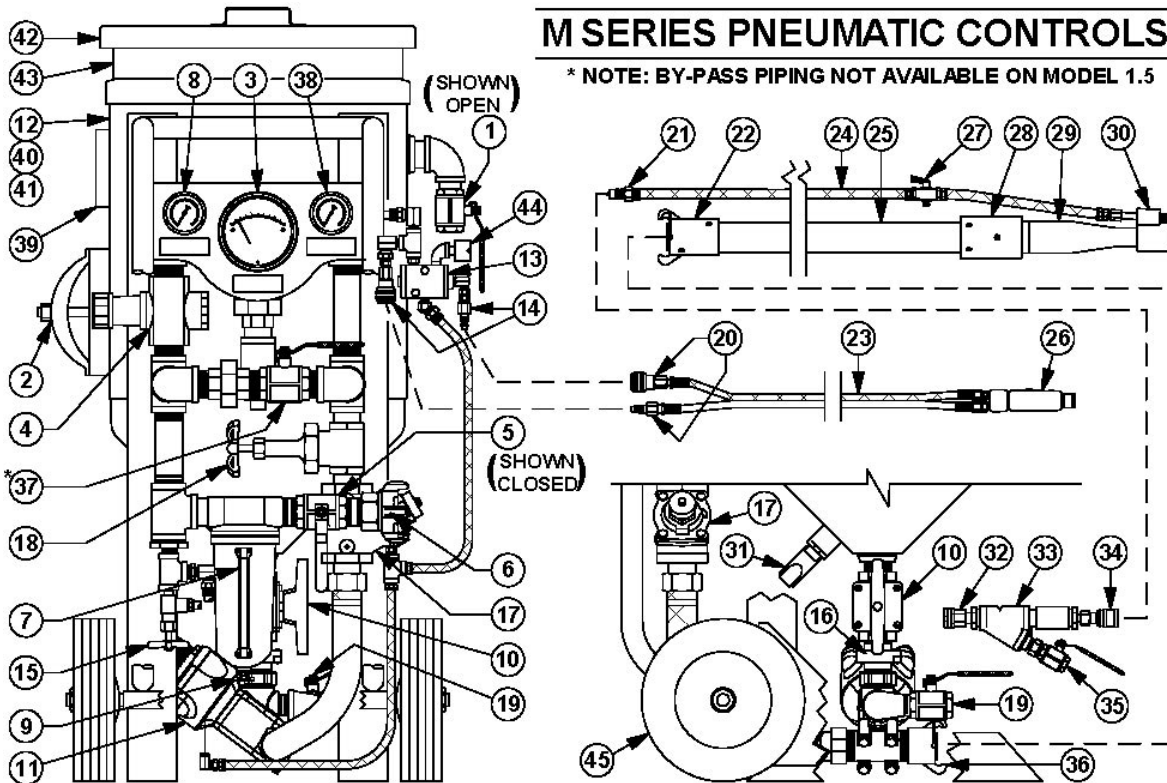

Figure 5.5 – Typical M Series Abrasive Blaster

5.14 Abrasive vibrator

The purpose of the abrasive vibrator (#31) is to vibrate the abrasive in the pressure vessel (#12). Some abrasives do not flow as well as others and the vibration to the vessel improves the flow into the Thompson Valve®. The level of vibration is controlled by the angle valve (#15) which can also turn off the vibration.

5.15 Water System

The water system of the M Series gives the operator the option to wet blast. Fine abrasives such as sodium bicarbonate create dust clouds that reduce visibility. The water mist created by the wet blast attachment (#30) reduces the dust cloud. A standard garden water hose is connected to the hose connection (#32). The water then flows through and is filtered by the y-strainer (#33). The y-strainer has a fine screen to remove small particles of debris that may clog up the atomizing tip of the wet blast attachment (#30). Trash collected at the y-strainer element is flushed out by opening the drain ball valve (#35). The petcock valve (#27) allows the operator to control how much water is used or to turn the water off completely.

5.16 Blast Hose

The blast air/abrasive mixture flows from the Thompson Valve® to the blast nozzle (#29) through the blast hose assembly (#25). The typical length of the blast hose is 50ft; however blast hose extensions can be added for longer lengths. For higher efficiency keep the blast hose as short as possible. Increased blast hose length causes pressure drop at the blast nozzle which reduces the blast efficiency. For higher efficiency use a blast hose with an inside diameter that is three times the nozzle throat diameter. Keep blast hose as straight as possible. Sharp bends create high wear points. Static electricity is generated by the abrasive flow through the blast hose. To prevent static electrical shock to operating personnel only use static dissipating blast hose and install a grounding strap on the abrasive blaster.

5.17 Blast Nozzle

The blast nozzle (#29) is an important part of the blast operation since the size of it determines the air flow and abrasive requirement. The amount of air flow and abrasive determine how quick blasting can be done. The larger the nozzle, the more the air and abrasive will be needed. The larger the nozzle size the greater the blast productivity. However, for a fixed amount of air supply, increasing the nozzle size will reduce the blast pressure. For best performance the blast pressure must be maintained as high as possible. Therefore, select the nozzle size based on the amount of air available and then adjust the abrasive flow at the Thompson Valve® accordingly.

The nozzle size can be identified by a small number visible on the outside. This number represents the nozzle throat diameter in sixteenths of an inch; for example, a #5 nozzle has a throat diameter of 5/16". See the tables in section 13.0 for approximate air and abrasive consumption for each nozzle. **Note:** For the best possible mixture of air to abrasive, the blast hose and piping must be at least three times the size of the blast nozzle.

5.18 Hose Connection

All air hose, blast hose, and threaded couplings have pin holes that align when connected. To prevent accidental hose disconnections safety pins must be installed through these holes. As a secondary safety measure each hose connection should also include a hose whip check that will hold the hose if there is an accidental disconnection. Connect one loop to each side of the connection and stretch out as shown in Figure 5.6 below. All air hose, blast hose, and threaded couplings have a gasket that seals the connection and should be replaced when air is leaking.

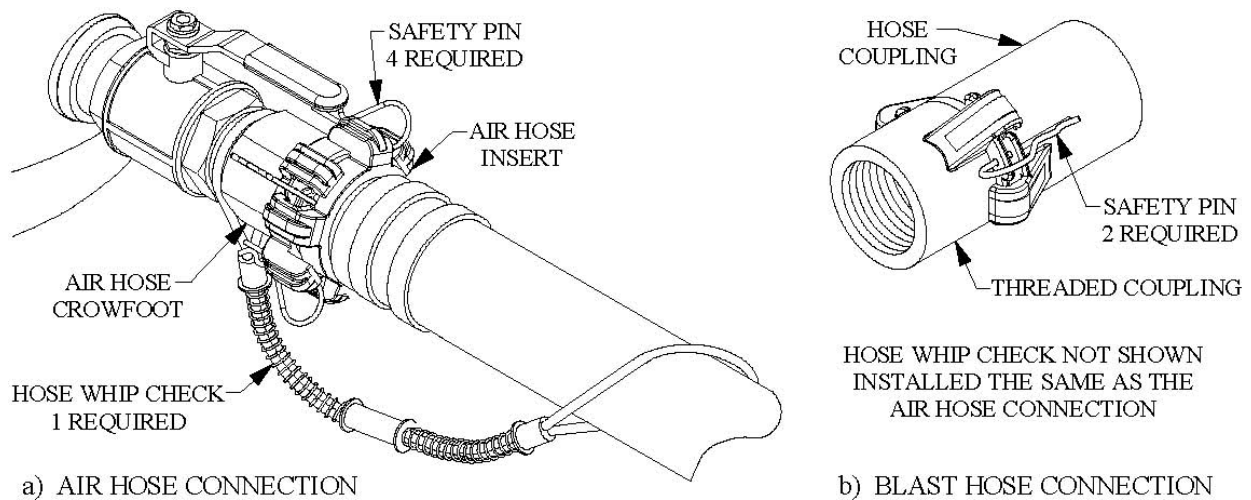

Figure 5.6 – Hose Connection Disconnect Protection

6.0 Pre-operation Procedures

DANGER

Failure to follow the procedures below could result in serious injury or death. In addition to these procedures completely read and understand all sections of this *M Series Abrasive Blaster Operation and Maintenance Manual*.

DANGER

The M Series Abrasive blaster is a pressurized vessel. Propelled objects will cause serious injury or death. Depressurize vessel before performing any maintenance. See Section 6.2.

6.1 M Series Abrasive Blaster Setup Procedure (see Figure 6.2)

6.1.1. Static electricity is generated by the abrasive flow through the blast hose. To prevent static electrical shock to operating personnel only use static dissipating blast hose and install a grounding strap on the abrasive blaster.

6.1.2. Do Not operate this equipment without a pressure relief device in place. The ASME Code requires that all vessels be provided with pressure relief devices.

Local regulations set the specifications for pressure relief valves; therefore it is the responsibility of the owner of the abrasive blaster to install a pressure relief valve that meets *all* applicable regulations. The pressure relief device must be set at the maximum allowable working pressure of the abrasive blaster. See the ASME vessel nameplate (#39).

6.1.3. Make certain that the M Series Abrasive blaster is not pressurized. Follow the depressurizing procedure given in Section 6.2.

WARNING

Airborne particles and loud noise hazards from blowdown exhaust air can cause serious injury and loss of hearing. Wear approved eye and ear protection. Stay clear of blowdown air path. **DO NOT** place hands or other body parts in the blowdown air path. Make sure no personnel are in the blowdown air path.

6.1.4. Properly install the handway cover (#2) and gasket. See Section 6.3.

6.1.5. Verify that all required personal protective equipment is available for each operator and in good operating condition (safety glasses, safety shoes, ear plugs, gloves, airline filter, respirator, & carbon monoxide monitor). *Critical: Adhere to all local, state, and federal regulations including, but not limited to, OSHA (Occupational Health and Safety Administration). Pay close attention to requirements regarding breathing air quality. When an oil-lubricated air compressor is used, additional requirements for a high temperature alarm and/or a carbon monoxide monitor become necessary. See Sections 3.8 and 3.9.*

WARNING

Failure to use personal protective equipment could result in serious injury or death.

- 6.1.6. Screw nozzle (#29) into the nozzle holder at end of the blast hose assembly (#25).
- 6.1.7. Slide the wet blast attachment (#30) over the end of the blast nozzle (#29).
- 6.1.8. Hose clamp the deadman (#26) to the blast hose assembly in a comfortable position behind the nozzle holder.
- 6.1.9. Connect the male fitting at the end of the wet blast water line (#24) to the swivel fitting on the wet blast attachment (#30).
- 6.1.10. Wire tie the wet blast water line (#24) and the twinline hose (#23) or electric deadman extension cords to the blast hose (#25).
- 6.1.11. Connect the blast hose coupling (#22) to the hose coupling (#36) on the Thompson Valve® (#11). Then install safety pins and a hose whip check to prevent accidental disconnections during operation. See Section 5.18 and 8.7.

▲ WARNING

Failure to install safety pins on all blast hose couplings could result in serious injury or death. See Section 5.18 and 8.7.

- 6.1.12. Connect the twinline hose quick disconnects (20) or the electric deadman extension cord to the mating disconnects on the M Series Abrasive blaster piping (#14).
- 6.1.13. Connect the wet blast water line quick disconnect (#21) to the quick disconnect (#34) on the y-strainer.
- 6.1.14. Connect a standard garden hose to the water inlet connection (#32) on the y-strainer.
- 6.1.15. Connect a 150 psi rated (minimum) air supply hose to the air inlet crowfoot (#6) and install safety pins and a hose whip check to prevent accidental disconnections during operation. See Section 5.18 and 8.7.

▲ WARNING

Failure to install safety pins on all air hose couplings could result in serious injury or death. See Section 8.7.

6.2 M Series Abrasive Blaster Depressurizing Procedure (Blowdown)

- 6.2.1. Close the air inlet ball valve (#5). The ball valve is closed when the handle is fully turned to the position shown in Figure 6.2 (handle perpendicular to body). The handle tab will bottom against the ball valve body in the closed position.
- 6.2.2. Slowly open the blowdown ball valve (#1). As the blowdown ball valve (#1) is opened air pressure inside will exhaust out and depressurize the blast vessel (#12).

⚠ WARNING

Airborne particles and loud noise hazards from blowdown exhaust air can cause serious injury and loss of hearing. Wear approved eye and ear protection. Stay clear of blowdown air path. **DO NOT** place hands or other body parts in the blowdown air path. Make sure no personnel are in the blowdown air path.

- 6.2.3. The M Series Abrasive blast vessel (#12) is completely depressurized when the air inlet ball valve (#5) is closed and the blowdown ball valve (#1) is open with no airflow from it. The popup head (#41) will fall open when the blast vessel is completely depressurized.

⚠ WARNING

When the popup valve opens after depressurizing abrasive can be blown out of the blast vessel and into the face and eyes of the operator. Wear OSHA approved safety glasses. See Section 3.9.

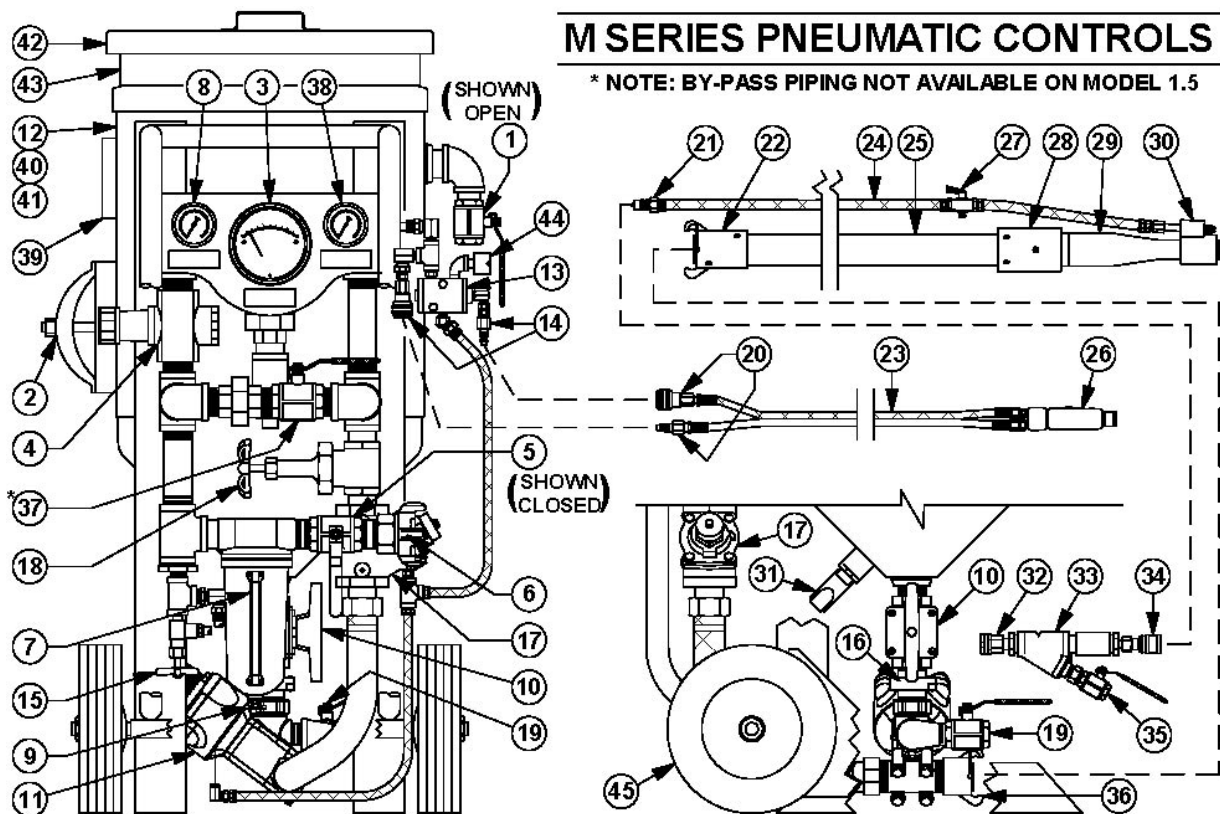

Figure 6.1 – Typical M Series Abrasive Blaster

6.3 Handway Cover Installation Procedure (See Figure 6.5(a))

- 6.3.1. Check that the handway cover, crab, bolt, and gasket are dimensionally correct for the size handway weld ring of the pressure vessel.
 - a) Measure and write down the inside dimensions “A” and “B” of the handway weld ring. See Figure 6.5(a).
 - b) Verify the size of the handway assembly by comparing the weld ring measurements from step “a” to the dimensions shown in Table 6.5(c).
 - c) Verify that the dimensions of the cover, crabs, bolts, and gasket match the corresponding dimensions given in Table 6.5(c). **Note:** The actual dimensions may vary by up to 1/4" from those given in Table 6.5(c).
 - d) Replace any component that is not dimensional correct. Incorrect dimensions indicate that the component is part of a different size handway assembly.



The handway assembly is part of a Pressurized Vessel. Use of incorrect handway components will result in assembly failure. Assembly failure will propel objects causing serious injury or death.

- 6.3.2. Inspect the handway gasket for tears, cracks, or other wear. Replace if necessary.
- 6.3.3. Inspect the handway weld ring sealing surface inside the vessel. Inspect the handway cover sealing surface. Both surfaces must be smooth.
- 6.3.4. Place the gasket on the handway cover then fit both through the opening.
- 6.3.5. Place the cover and gasket in position against the inside edge of the handway weld ring. Apply a pulling force to hold in position then proceed.
- 6.3.6. Center the gasket on the handway weld ring.
- 6.3.7. Center the handway cover on the gasket.
- 6.3.8. Center the handway crab on the outside weld ring.
- 6.3.9. Slide the handway crab bolt to the inside edge of the slot before tightening. See Figure 6.5(a).
- 6.3.10. When all components are centered and the crab bolt is bottomed in the slot, tighten the nut onto the bolt with a wrench until snug.
- 6.3.11. Only after completing all the pre-operation procedures in Section 6.0 and the abrasive blast vessel is then pressurized, re-tighten the nut with a wrench until snug again.
- 6.3.12. Do not over-tighten the crab nut and bolt. Over-tightening could bend the crab out of shape resulting in malfunction of the assembly.
- 6.3.13. Periodically check for leaks.

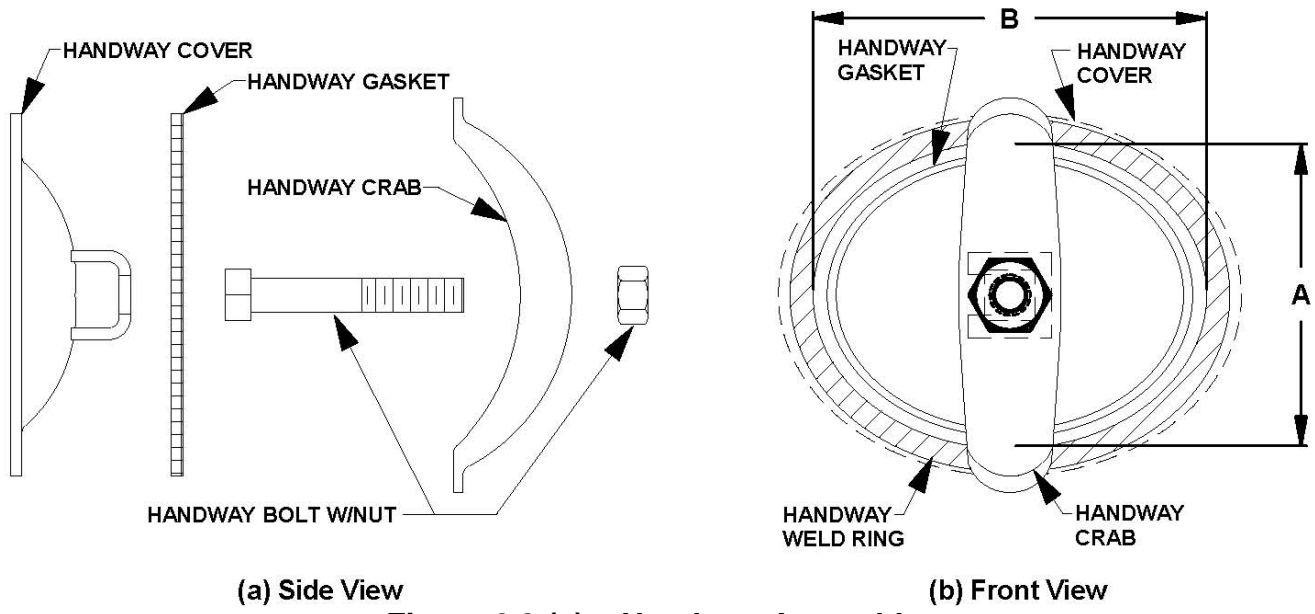

Figure 6.3 (a) – Handway Assembly

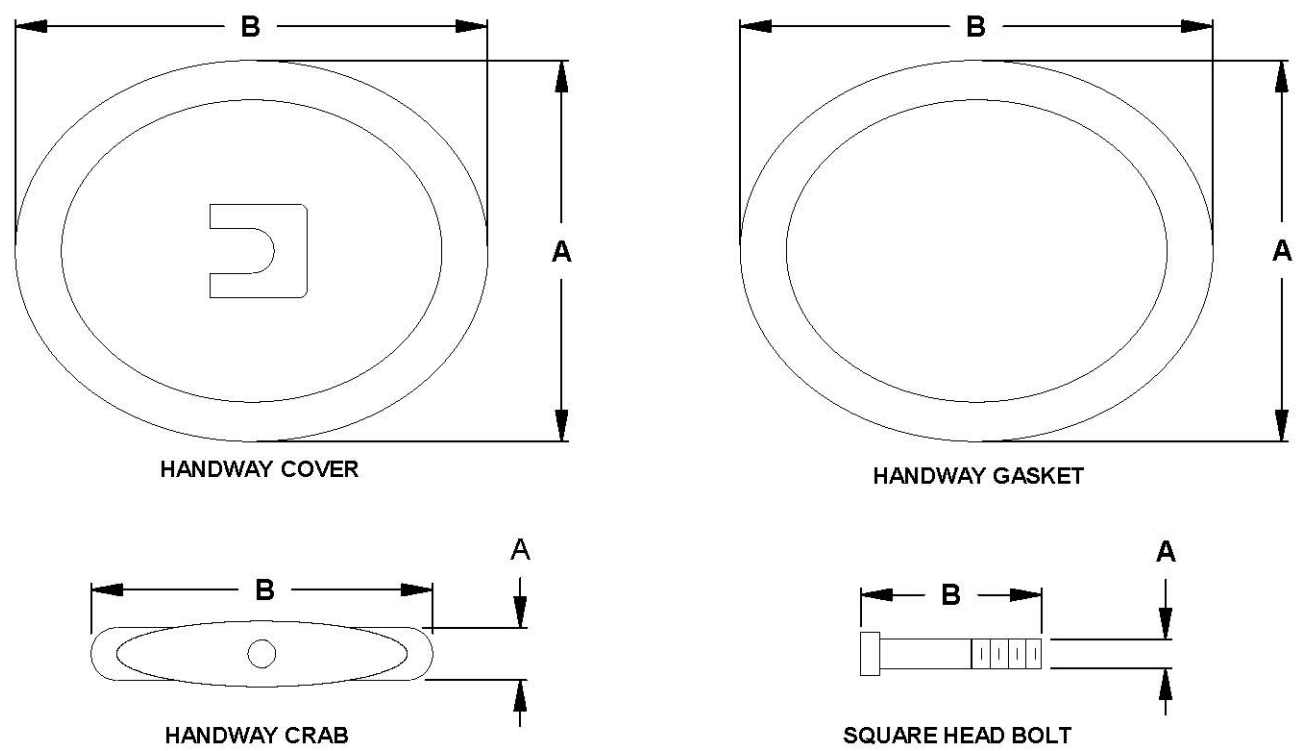

Figure 6.3 (b) – Handway Components

6" x 8" Handway Dimensions		
Component	A	B
Weld Ring	6-5/8"	8-1/2"
Handway Cover	7-11/16"	9-7/8"
Handway Gasket	7-3/4"	9-3/4"
Handway Crab	2-3/8"	8-3/4"
Square Head Bolt	3/4"-10 UNC	4-1/2"

Table 6.3 (c) – Handway Component Dimensions

7.0 Operating Instructions

7.1 Filling The M Series Abrasive Blaster With Abrasive

7.1.1. The M Series Abrasive blaster must be completely depressurized before filling can begin. Follow the depressurizing procedure in Section 6.2.

⚠ WARNING

Airborne particles and loud noise hazards from blowdown exhaust air can cause serious injury and loss of hearing. Wear approved eye and ear protection. Stay clear of blowdown air path. **DO NOT** place hands or other body parts in the blowdown air path. Make sure no personnel are in the blowdown air path.

7.1.2. Remove the vessel lid (#42) and screen (#43) to check that the popup (#41) has dropped open. This indicates that the blast vessel is depressurized. See Figure 7.1.

7.1.3. Fill the M Series Abrasive blaster with dry abrasive through the screen (#43) to remove unwanted trash. Do not over-fill the blast vessel. An excessive amount of abrasive piled above the popup (#41) after the blast vessel is full may prevent the popup from closing and sealing properly.

⚠ WARNING

Pinch point hazard. Vessel pressurization will close the popup. Keep fingers clear of the popup opening. Disconnect air supply prior to performing popup maintenance.

7.1.4. Only after completing all the pre-operation procedures in Section 6.0 and 7.1, and the M Series Abrasive blast vessel is then pressurized per Section 7.2, check the popup for leaks. Periodically check the popup for leaks thereafter.

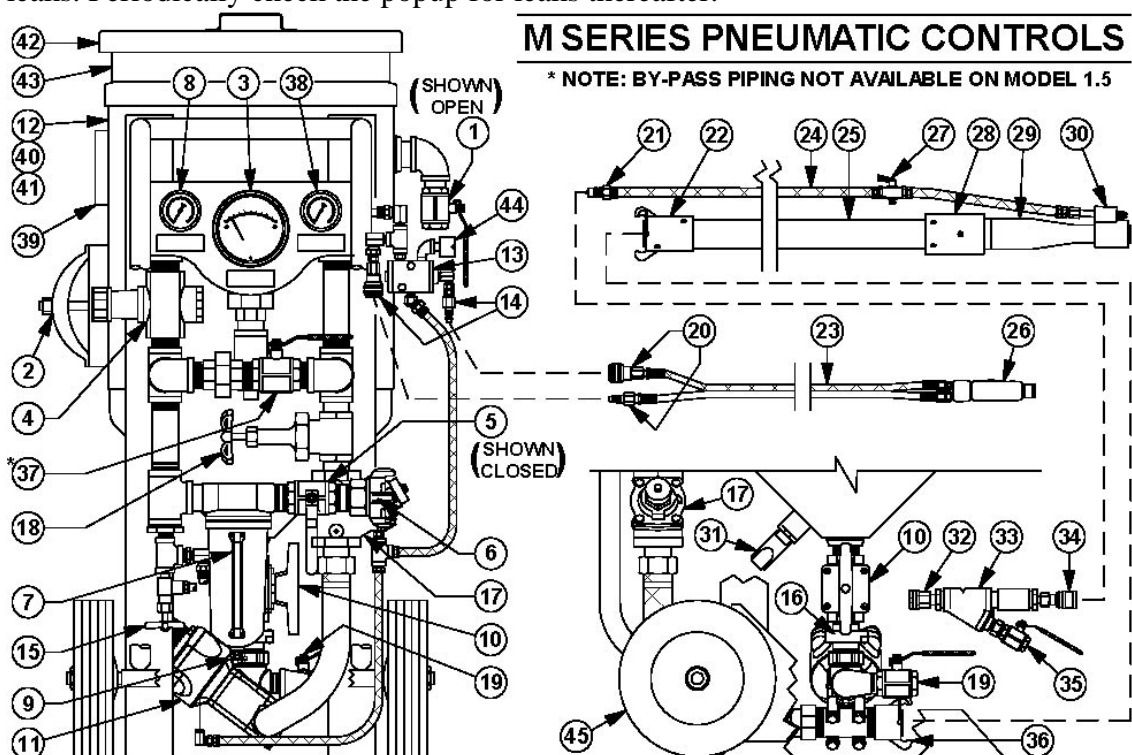

Figure 7.1 – Typical M Series Abrasive Blaster

7.2 Beginning the Blasting Operation (See Figure 7.3)

- 7.2.1. The M Series abrasive blaster must be properly prepared and all operating personnel must be thoroughly trained before beginning the blast operation. Completely read and understand all sections of this manual before beginning the blast operation. See the pre-operation procedures given in Section 6.0.
- 7.2.2. Perform the required inspections and maintenance before beginning the blast operation. See the instructions given in Section 8.0.



The M Series Abrasive blaster is a Pressurized Vessel. Propelled objects will cause serious injury or death. Depressurize vessel before performing any maintenance. See Section 6.2.

- 7.2.3. Fully open both the abrasive shutoff valve (#10) and gate valve (#18).
- 7.2.4. If wet blasting will be used turn on the water supply to the y-strainer (#33).
- 7.2.5. For initial startup back the knob of the air pressure regulator (#4) all the way out by turning the knob counterclockwise until no resistance is felt. Then turn the knob clockwise a few turns for a low initial pressure setting. Further adjustment can be made later as needed.
- 7.2.6. Close the blowdown ball valve (#1). The ball valve is closed when the handle is perpendicular to the body.
- 7.2.7. The vessel may now be pressurized by slowly opening the air inlet ball valve (#5).
- 7.2.8. Check the popup, handway, hoses, and piping for leaks after pressurizing. Periodically check for leaks thereafter.
- 7.2.9. Slightly open the petcock valve (#9) on bottom of the air filter to permit moisture to continually drain during the blast operation. Once each day open completely to blow out excess accumulation.
- 7.2.10. The following steps are for blast pressure and abrasive flow setting which may require several adjustments and testing of the blast flow. It is recommended that testing of the blast be made on a test piece so not to damage anything of value.
- 7.2.11. Set the required tank pressure by turning the knob on the tank/blast pressure regulator (#4). Turn clockwise to increase pressure or counterclockwise to decrease pressure. The air regulator is non-relieving therefore a reduction of tank pressure change will not be evident on the gauge until blasting begins. For the most accurate setting, this adjustment should be made while blasting with the gate valve (#18) fully opened. This pressure is indicated by the tank pressure gauge (#8) while blasting. Bypass valve (#37) must be closed. **Note:** Further tank/blast pressure adjustment may be required when actual blasting is begun.

- 7.2.12. To operate at full pressure (without the restriction of the regulator) open the bypass ball valve (#37). This allows full air pressure into the control piping regardless of the air regulator adjustment. See Figure 7.3. **Note:** Bypass piping is not available on the M11.
- 7.2.13. Set preliminary abrasive flow by adjusting the knob on the Thompson Valve® (#11). Turn clockwise for less abrasive flow and counter clockwise for more abrasive. Due to the length of the blast hose there will be a slight delay in control of the abrasive flow at the nozzle, therefore allow a few seconds before adjusting further. **Note:** If the blaster is equipped with the optional abrasive cut-off feature the switch must be set to the “on” position to blast with abrasive. See Section 9.3.
- 7.2.14. With one hand grip the blast hose assembly (#25) and with the other hand press in the deadman safety button. To begin blasting, aim the blast nozzle at the object to be blasted, then firmly press down the deadman lever (#26). Air and blast abrasive will flow into the blast hose (#25) and out of the blast nozzle (#29). Release the deadman lever to stop blasting.



Do not aim blast nozzle towards yourself or any person. System malfunction can cause accidental start up and result in injury to personnel.

- 7.2.15. When using fine particle abrasives improved flow is achieved by using the differential pressure feature. Differential pressure is a slight higher pressure in the blast pot over that of the blast hose. This differential pressure allows the operator to precisely control the abrasive flow.

Use the gate valve (#18) to set the differential pressure. Adjust the differential pressure by turning the gate valve handle clockwise (to decrease blast pressure) or counterclockwise (to increase blast pressure). Decreasing the blast pressure increases the differential pressure and abrasive flow. Conversely, increasing the blast pressure decreases the differential pressure and hence decreases the abrasive flow. The ideal differential pressure is about a 2 psi greater tank pressure than blast pressure. The blast pressure is indicated by pressure gauge (#38). The differential pressure is shown by the larger gauge (#3).

Optimum differential pressure adjustment is done while blasting, therefore the operator should get assistance from a second person. It is important to remember that due to the length of the blast hose there will be a slight delay in control of the abrasive flow at the nozzle, therefore allow a few seconds before adjusting further.

- 7.2.16. With certain abrasives flow may be improved by use of the abrasive vibrator. Open the angle valve (#15) slightly to start the vibrator and turn counterclockwise to increase vibration. Turn the angle valve knob clockwise completely down to turn off the vibrator (#31).
- 7.2.17. Open the petcock valve (#27) on the blast hose water line if wet blasting is required for dust prevention.
- 7.2.18. Re-test the blast air and abrasive mixture again on a test piece to determine if further adjustment is needed. Release the deadman lever to stop blasting.

7.3 Ending the Blast Operation (See Figure 7.3)

- 7.3.1. Close the air inlet ball valve (#5). The ball valve is closed when the handle is fully turned to the position shown in Figure 7.3 (handle perpendicular to body). The handle tab will bottom against the ball valve body in the closed position.

CAUTION

Do not turn off the air compressor and allow the abrasive blaster air pressure to back flow through the air supply system. Back flow will carry abrasive into the air filter (#7) and contaminate the controls.

- 7.3.2. Completely open petcock valve (#9) at the bottom of the air filter (#7) to allow all the accumulated moisture to be drained out. Close the petcock after draining.

- 7.3.3. Completely depressurize the abrasive blast vessel (#12) by slowly opening the blowdown ball valve (#1). See Section 6.2 for blowdown procedure.

WARNING

Airborne particles and loud noise hazard from the blowdown exhaust air can cause serious injury and loss of hearing. Wear approved eye and ear protection. Stay clear of blowdown air path. DO NOT place hands or other body parts in the blowdown air path. Make sure no personnel are in the blowdown air path.

- 7.3.4. For long periods of non-usage remove remaining blast abrasive from blast vessel to prevent moisture contamination.

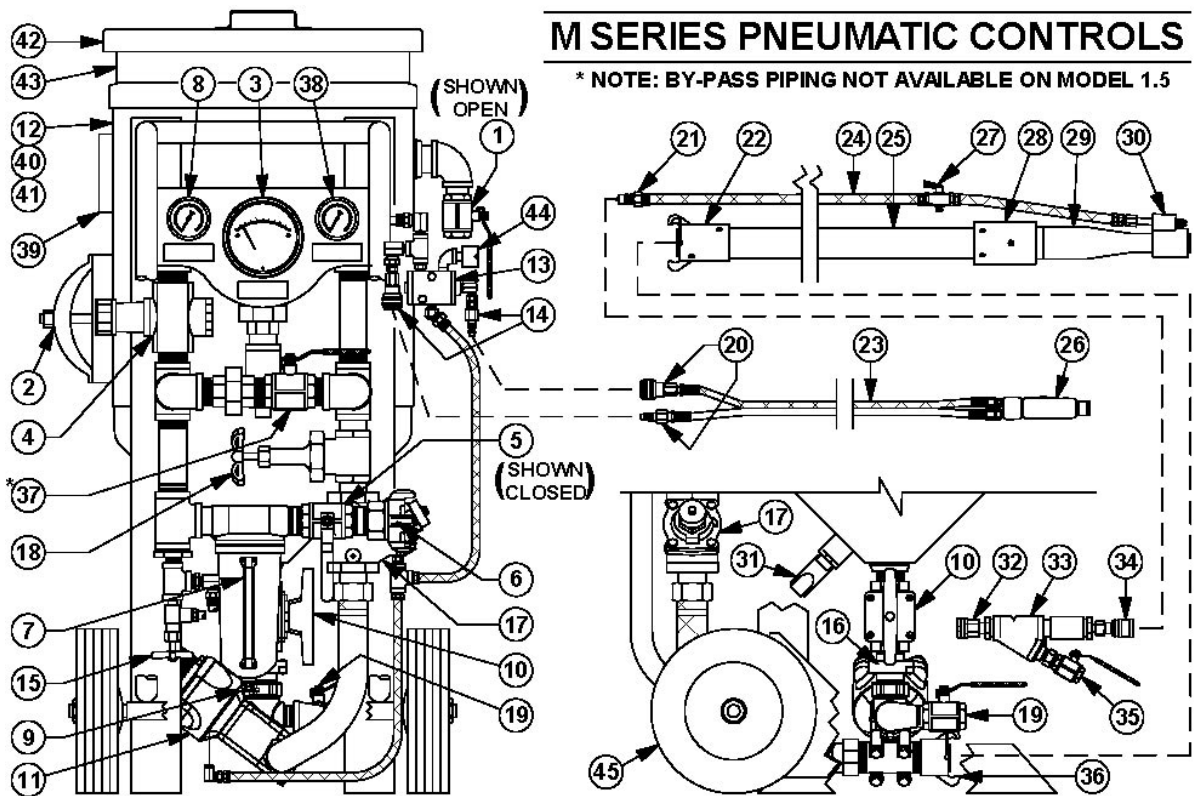

Figure 7.3 – Typical M Series Abrasive Blaster

8.0 Maintenance and Inspection Instructions

DANGER

The M Series Abrasive blaster is a Pressurized Vessel. Propelled objects will cause serious injury or death. Depressurize vessel before performing any maintenance. See Section 6.2.

- 8.1. The ASME Code is a standard covering materials, design, fabrication, and installation. Vessel integrity subsequent to purchase is the responsibility of the owner and/or user. At intervals required by state law and/or local authorities, the vessel should be subjected to a hydrostatic test as described in the ASME Code, Section VIII, Division 1. Do Not subject the abrasive blaster pressure vessel to a pneumatic proof test exceeding the maximum allowable working pressure. In no case should the hydrostatic test pressure exceed 1.3 times the maximum allowable working pressure (MAWP) shown on the pressure vessel nameplate (#39). Thoroughly clean and dry the vessel before re-assembly. Moisture or debris left in vessel can cause equipment malfunction.
- 8.2. Any damage to an abrasive blaster can make it unsafe. Inspect the exterior of the abrasive blast vessel daily for corrosion, pitting, or other damage (i.e. dents, gouges or bulges). If damaged, take out of service immediately and have it inspected and/or repaired by a qualified facility. Contact Axxiom Manufacturing, Inc. for technical support.
- 8.3. The interior condition of the abrasive blast vessel (#12) should be inspected quarterly. Pitting caused by corrosion will reduce the wall thickness of the vessel. If excessive corrosion is found, have the abrasive blast vessel inspected by a qualified facility. Contact Axxiom Manufacturing, Inc. for technical support.

Check the pressure vessel internal piping for corrosion, cracks, and holes. See Figure 8.1.

- 8.4. The popup alignment and operation is tested by the manufacturer, however vibration and creeping during shipment may cause the internal popup support piping to shift resulting in misalignment.. Prior to initial usage and periodically thereafter, the popup gap and alignment should be checked. Inspect the popup as follows:
 - a) Depressurize the M Series Abrasive blaster per Section 6.2.
 - b) Disconnect air supply hose from the crowfoot (#6).
 - c) Inspect the popup gasket (#40) and popup head (#41) sealing surfaces for wear or deformations. Replace either if necessary.
 - d) Check that the popup is centered within the gasket opening. If necessary, use a pry bar as a lever between the popup and gasket to deflect the internal support piping and shift the popup to the center of the gasket opening.
 - e) Check the popup gap (distance between the popup surface and the gasket). It should be between 0.625” and 0.840”. See Figure 8.1. An excessive gap is created by a vertical nipple that is too short. An excessive gap will expose the top of the vertical nipple to abrasive when the popup closes which could result in premature wear to the popup.
 - f) After checking the alignment and gap, the blast vessel can be re-pressurized and the popup is then checked for leaks. If a leak is present, repeat the above steps to isolate the problem.

WARNING

Pinch point hazard. Vessel pressurization will close the popup. Keep fingers clear of the popup opening. Disconnect air supply prior to performing popup maintenance.

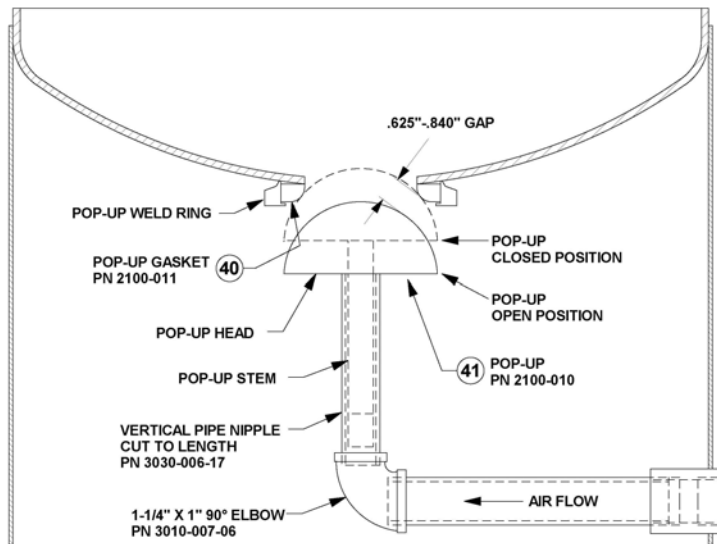

Figure 8.1 – Standard popup assembly

- 8.6. All air hoses, blast hoses, control hoses, and wires should be inspected daily for wear, dry rotting, cracking or leakage. Repair or replace any hoses or wires that show any signs of wear, leakage or other damage. Damaged wires and/or hoses can cause system malfunctions and can result in serious injury or death to operating personnel.

Blast hoses are a high wear component of the abrasive blast system. Sharp bends in the blast hose create high wear points resulting in soft spots that can rupture while blasting. Check the full length of the blast hose assembly for soft spots caused by wear. To prevent serious injury to personnel replace blast hoses with soft spots. Note: Static electricity is generated by the abrasive flow through the blast hose. To prevent static electrical shock to operating personnel only use static dissipating blast hose and install a grounding strap on the abrasive blaster.

WARNING

Worn blast hose assemblies can rupture while blasting and the resulting abrasive blast stream can cause serious personal injury.

- 8.7. All air hose, blast hose, and threaded couplings have pin holes that align when connected. To prevent accidental hose disconnections safety pins must be installed through these holes. Each hose connection must also include a hose whip check that will hold the hose if there is an accidental disconnection. Connect one loop to each side of the connection and stretch out as shown in Figure 8.2 below. Check hose connections daily and replace missing or damaged pins and whip checks.

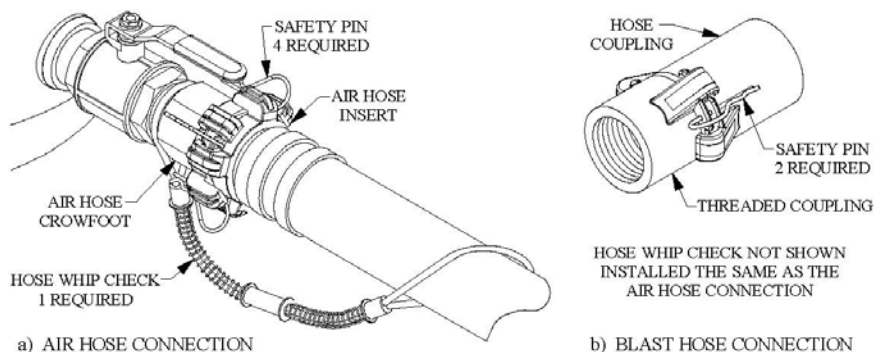

Figure 8.2 – Hose Connection Disconnect Protection

- 8.8. All air hose, blast hose, and threaded couplings have gaskets that seal the connection. To prevent loss of air pressure and/or premature abrasive wear replace these gaskets when leaks are found. Inspect the couplings daily for leaks and wear. Replace gaskets when visible wear or leaks are found. When installing or replacing hose couplings cut the hose end square for secure fit (see Figure 8.3). To insure proper coupling connection always use fittings that are the same brand. See the drawings and part lists in Section 9.1 and 9.2.

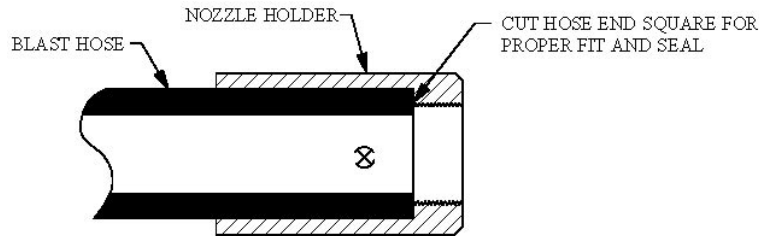

Figure 8.3 – Hose End Fit up

- 8.9. Remove the blast nozzle daily and check the jacket and thread condition. Check nozzle throat diameter. An over-sized throat diameter reduces blast efficiency. Replace the blast nozzle if worn or damaged.
- 8.10. Thompson Valves, Automatic air valves, control valves, and deadman valves should be disassembled and inspected quarterly, or more frequently if heavily used. The Thompson Valve cylinder should be cleaned and lubricated with an anti-seize compound. Replace parts as needed with Schmidt® original factory replacement parts furnished by an authorized Schmidt distributor. Periodically check if air is leaking from end of blast nozzle when the blast operation is off. A worn Thompson Valve® seat usually causes this. It is replaced by removing the four bolts in the base of the valve to allow disassembly. Refer to valve drawings in Sections 9.0.

⚠ DANGER

Depressurize vessel before performing any maintenance. See Section 6.2. Removing the Thompson valve bolts with the abrasive blaster pressurized will result in serious injury or death.

⚠ WARNING

Use of replacement components that are not Schmidt original factory replacement parts may result in equipment failure which can result in serious personal injury.

- 8.11. Check daily to verify that all personal protective equipment is available for each blast operator. Check daily to verify that all personal protective equipment is in good operating condition. Consult the operating and maintenance instructions provided by the manufacturer of each PPE item. See Section 3.9 and reference OSHA 29 CFR 1910 Subpart I.

⚠ WARNING

Failure to use personal protective equipment could result in serious injury or death.

- 8.12. Check monthly to verify that all the warning decals are in position and legible. See Section 0.0 for full descriptions and locations.

⚠ DANGER

Failure to maintain warning decals risks the possibility of not alerting the abrasive blaster operator to potential dangers which can result in serious injury or death. See Section 0.0.

8.13. Maintenance Schedule Quick Reference Chart

M SERIES ABRASIVE BLASTER MAINTENANCE SCHEDULE					
ITEM	MAINTENANCE REQUIRED	DAILY	WEEKLY	MONTHLY	QUARTERLY
Blaster Vessel	Hydrostatic Test See Section 8.1	As required by state law and/or local authorities			
Blaster Vessel	Check for exterior damage (corrosion, dents, bulges). See Section 8.2	X			
Blaster Vessel	Check for interior damage (corrosion / pitting). See Section 8.3				X
Popup	Check sealing surfaces, alignment and gasket to popup gap. See Section 8.4	X			
Blast & Air Hoses	Check hoses for soft spots, wear, cracks, or air leaks See Section 8.6	X			
Remote Control Hoses	Check hoses for soft spots, wear, cracks, or air leaks See Section 8.6	X			
Remote Control Wires	Check wiring for bare spots, fraying, or cracks See Section 8.6	X			
Blast & Air Hose Couplings	Check for safety pins and whip checks See Section 8.7	X			
Hose Coupling Gaskets	Check for leaky air and blast hose coupling gaskets See Section 8.8	X			
Blast Nozzle	Check blast nozzle threads and jacket and for air leaks See Section 8.9	X			
Valves	Disassemble, inspect, and lubricate. See Section 8.10				X
Personal Protective Equipment	Check condition of all personal protective equipment See Section 3.9 and 8.11	X			
Warning Decals	Check the condition of warning decals. See Sections 0.0 and 8.12			X	

THIS PAGE INTENTIONALLY BLANK

9.0 Drawings and Parts Lists

The following pages contain drawings representing typical blast control systems and components. Determine the type of control system the abrasive blast system is equipped with (pneumatic or electric controls) then reference the appropriate drawing and parts list to determine the required parts. To insure the proper operation of the blast system only use Schmidt® original factory replacement parts furnished by an authorized Schmidt distributor. See Section 1.34 and Section 12.2.12.

9.1(a) M11 Abrasive Blaster with Pneumatic Control System

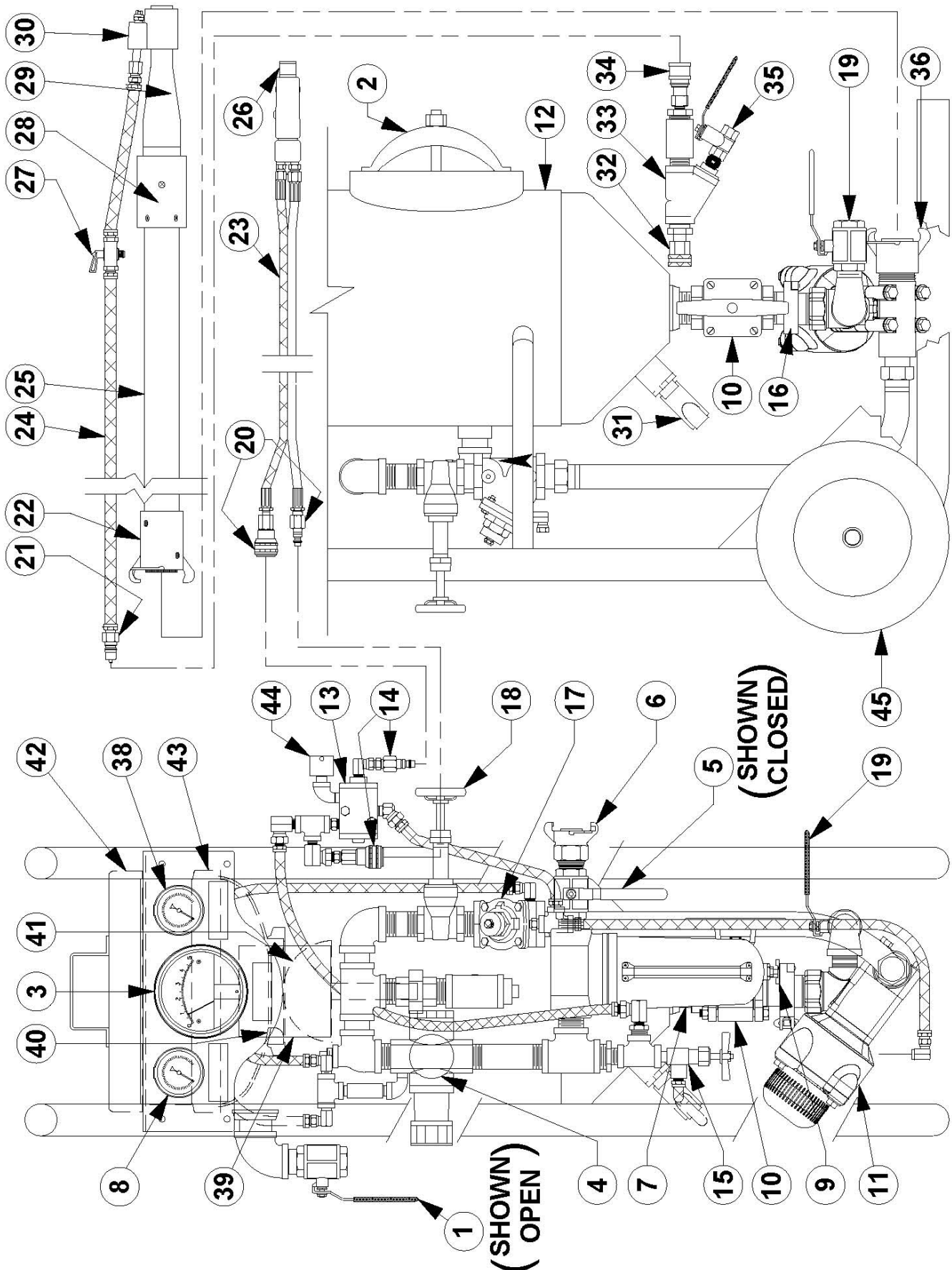

9.1(b) M11 Abrasive Blaster Pneumatic Control Parts List

ITEM	PART NUMBER	DESCRIPTION	ITEM	PART NUMBER	DESCRIPTION
1	2401-504	Blowdown ball valve 1/2"	23	4100-501	Twinline hose assembly, 3/16 x 55'
2	7000-001-11	Handway, crab assembly 6" x 8"	24	4101-002	Water hose, 1/4" push on
3	2010-013	Differential Pressure Gauge, 0-5 psi	25	4104-XXX-XX	Blast hose assembly
*4	2003-006	Air pressure regulator	26	2263-002	G2 Deadman valve
*5	2401-506	Air inlet ball valve	27	2024-001	Petcock valve, 1/4"F x 1/4"F
*6	4208-106	Crowfoot	28	4215-XXX	Nozzle holder
*7	2302-206-50	Air filter, 50 micron	29	5000-XXX	Blast nozzle
8	8710-40007A	Tank pressure gauge, 0-160 psi	30	8020-000-02	Wet blast attachment assembly
9	-----	Drain valve for air filter	31	2020-013	Vibrator
10	8710-36101	Media Valve Shut-off, 1-1/4"	32	4227-304-05	Garden hose coupling
*11	2152-216	Thompson Valve II® w/slotted sleeve		4227-305-99	Garden hose gasket, 3/4"
12	8720-011-01	Blast pot, M Series Model M11	33	2300-305-02	Y-strainer, 60 mesh 3/4"
13	2229-000	Control valve, pneumatic	34	4224-711-02	Water quick connect socket, 1/4"
14	4224-300-02	Quick connect plug, 1/4"	35	2401-502	Drain ball valve, 1/4"
	4224-301-02	Quick connect socket, 1/4"	36	4214-108-01	Threaded coupling
15	2430-804	Vibrator control angle valve, 1/4"	37	-----	Full pressure bypass ball valve
16	8710-92301S	Tri-Clamp, 1-1/2"	38	8710-40007A	Blast pressure gauge, 0-160 psi
17	8720-000-02	Automatic air valve 1"	39	-----	Pressure vessel nameplate
	2014-300	Breather vent, 1/8"	40	2100-011	Popup Gasket
18	2423-906	Gate valve, blast pressure control	41	2100-010	Popup Head
19	2401-506	Cleanout ball valve, 1" (TVII)	42	5010-010	Lid, 12"
20	4224-300-02	Quick connect plug, 1/4"	43	5011-010	Screen, 12" (1/4" mesh)
	4224-301-02	Quick connect socket, 1/4"	44	2013-402	Dust eliminator, 1/4" mnpt
21	4224-710-02	Water quick connect plug, 1/4"	45	7046-003	Wheel & Tire
22	4213-XXX	Blast hose coupling		7019-519	Nylock Nut 3/4"

9.1(c) M21/M31 Abrasive Blaster with Pneumatic Control System

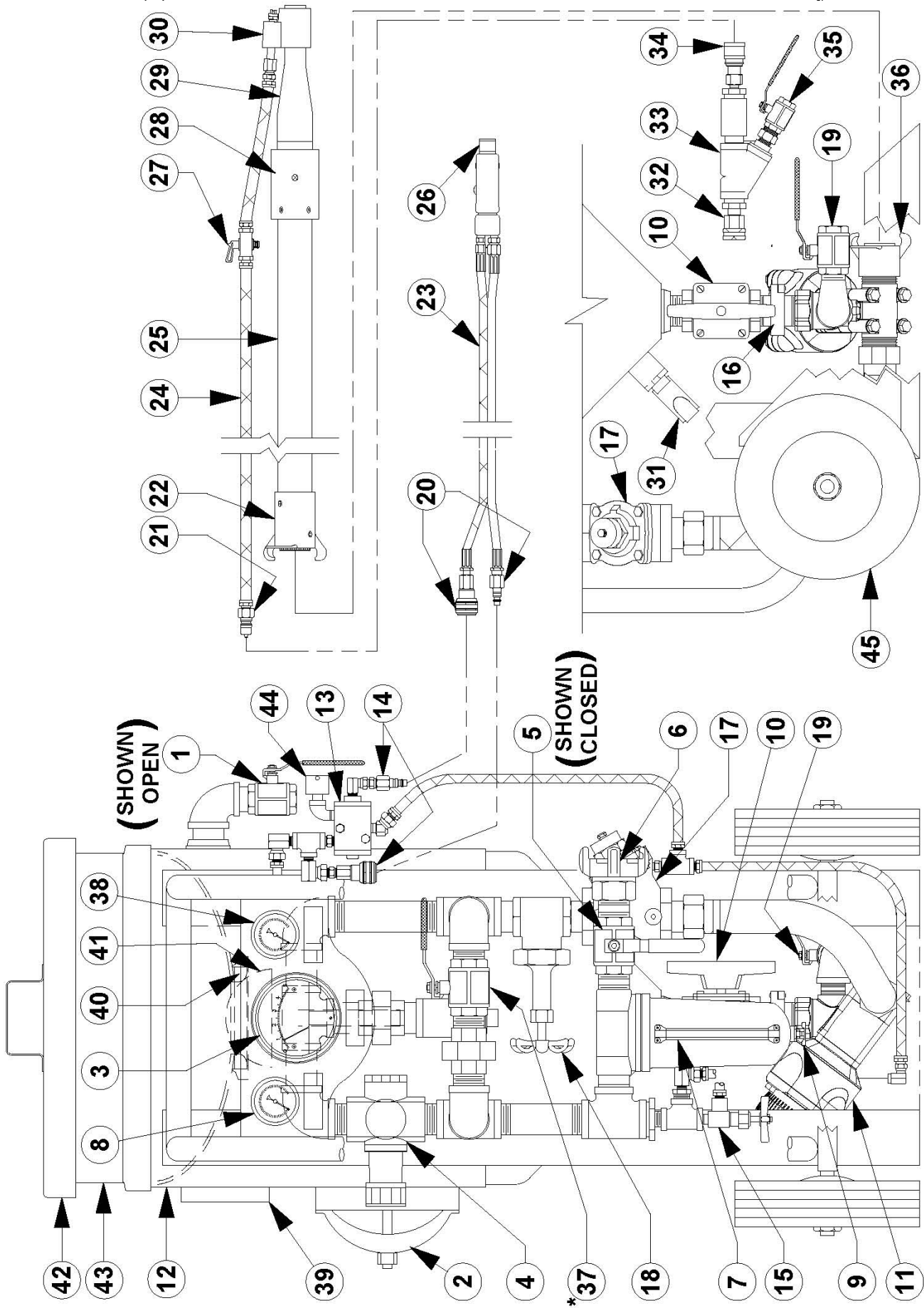

9.1(d)

M21/M31 Abrasive Blaster Pneumatic Control Parts List

ITEM	PART NUMBER	DESCRIPTION	ITEM	PART NUMBER	DESCRIPTION
1	2401-504	Blowdown ball valve 1/2"	23	4100-501	Twinline hose assembly, 3/16 x 55'
2	7000-001-11	Handway crab assembly, 6" x 8"	24	4101-002	Water hose, 1/4" push on
3	2010-013	Differential Pressure Gauge, 0-5 psi	25	4104-XXX-XX	Blast hose assembly
*4	2003-007	Air pressure regulator	26	2263-002	G2 Deadman valve
*5	2401-507	Air inlet ball valve	27	2024-001	Petcock valve, 1/4"F x 1/4"F
*6	4211-107	Crowfoot, 4-lug	28	4215-XXX	Nozzle holder
*7	2302-207-50	Air filter, 50 micron	29	5000-XXX	Blast nozzle
8	8710-40007A	Tank pressure gauge, 0-160 psi	30	8020-000-02	Wet blast attachment assembly
9	-----	Drain valve for air filter	31	2020-025	Vibrator
10	8710-36101	Media Valve Shut-off, 1-1/4"	32	4227-304-05	Garden hose coupling
*11	2152-217	Thompson Valve II® w/slotted sleeve		4227-305-99	Garden hose gasket, 3/4"
12	8720-021-01	Blast pot, M Series Model M21	33	2300-305-02	Y-strainer, 60 mesh 3/4"
	8720-031-01	Blast pot, M Series Model M31	34	4224-711-02	Water quick connect socket, 1/4"
13	2229-000	Control valve, pneumatic	35	2401-502	Drain ball valve, 1/4"
14	4224-300-02	Quick connect plug, 1/4"	36	4214-107-01	Threaded coupling
	4224-301-02	Quick connect socket, 1/4"	37	2401-507	Full pressure bypass ball valve
15	2430-804	Vibrator control angle valve, 1/4"	38	8710-40007A	Blast pressure gauge, 0-160 psi
16	8710-92301S	Tri-Clamp, 1-1/2"	39	-----	Pressure vessel nameplate
17	2123-107	Automatic air valve	40	2100-011	Popup gasket
	2014-300	Breather vent, 1/8"	41	2100-010	Popup head
18	2423-907	Gate valve, blast pressure control	42	5010-060	Lid, 24"
19	2401-506	Cleanout ball valve, 1" (TVII)	43	5011-060	Screen, 24" (1/4" mesh)
20	4224-300-02	Quick connect plug, 1/4"	44	2013-402	Dust eliminator, 1/4" mmpt
	4224-301-02	Quick connect socket, 1/4"	45	7046-003	Wheel & Tire
21	4224-710-02	Water quick connect plug, 1/4"		7019-519	Nylock Nut 3/4"
22	4213-XXX	Blast hose coupling			

9.2(a) M11 Abrasive Blaster with Electric Control System

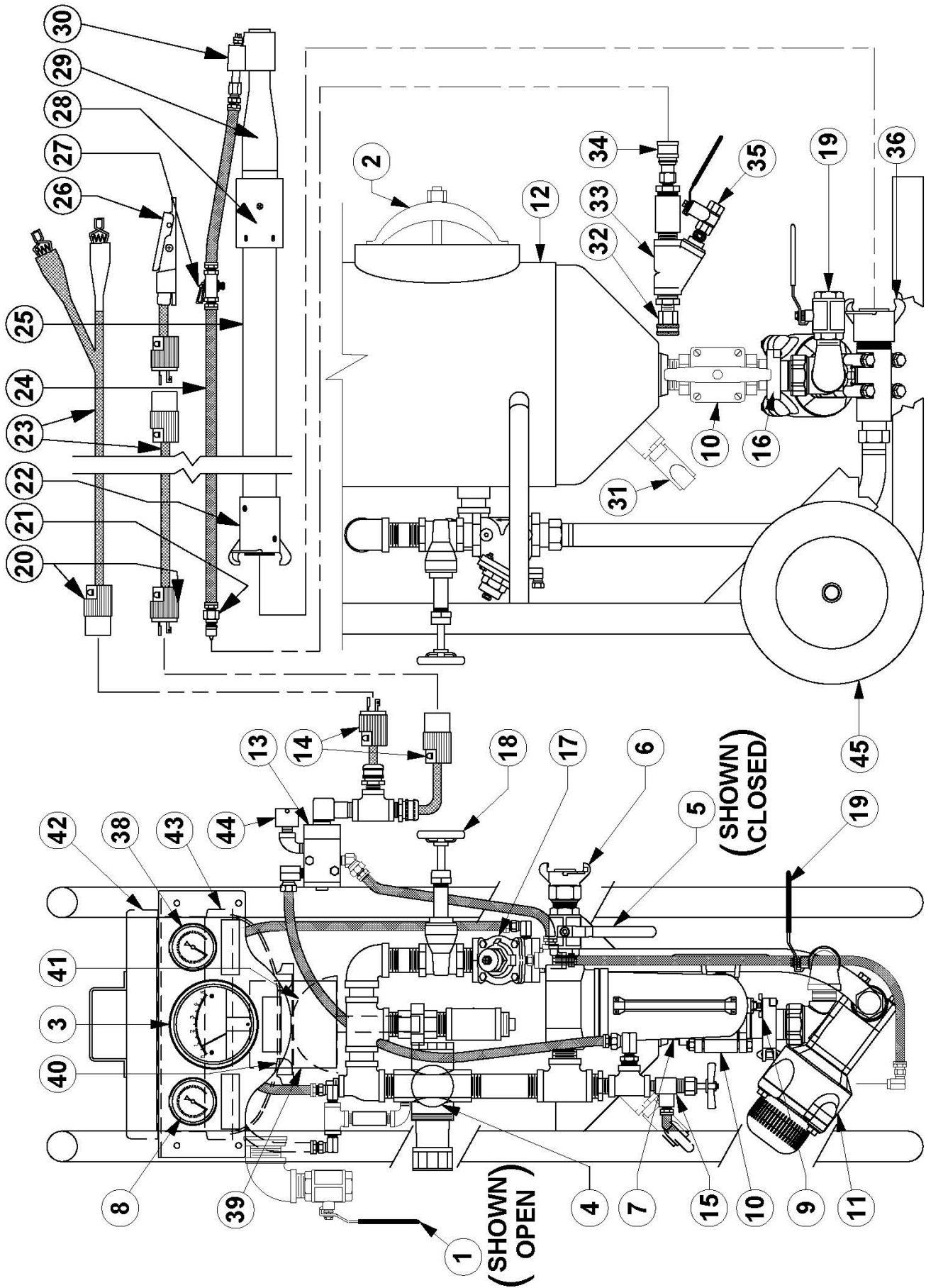

9.2(b) M11 Abrasive Blaster Electric Control Parts List

ITEM	PART NUMBER	DESCRIPTION	ITEM	PART NUMBER	DESCRIPTION
1	2401-504	Blowdown ball valve 1/2"	24	4101-002	Water hose, 1/4" push on
2	7000-001-11	Handway, crab assembly 6" x 8"	25	4104-XXX-XX	Blast hose assembly
3	2010-013	Differential Pressure Gauge, 0-5 psi	26	2263-400-01	Deadman switch w/plug
*4	2003-006	Air pressure regulator	27	2024-001	Petcock valve, 1/4"F x 1/4"F
*5	2401-506	Air inlet ball valve	28	4215-XXX	Nozzle holder
*6	4208-106	Crowfoot	29	5000-XXX	Blast nozzle
*7	2302-206-50	Air filter, 50 micron	30	8020-000-02	Wet blast attachment assembly
8	8710-40007A	Tank pressure gauge, 0-160 psi	31	2020-013	Vibrator
9	-----	Drain valve for air filter	32	4227-304-05	Garden hose coupling
10	8710-36101	Media Valve Shut-off, 1-1/4"	33	4227-305-99	Garden hose gasket, 3/4"
*11	2152-216	Thompson Valve II® w/slotted sleeve	34	2300-305-02	Y-strainer, 60 mesh 3/4"
12	8720-011-01	Blast pot, M Series Model M11	35	4224-711-02	Water quick connect socket, 1/4"
13	See Section 9.6	Control valve, electric	36	2401-502	Drain ball valve, 1/4"
14	7109-301	Electric plug, 3-prong twist lock	37	4214-108-01	Threaded coupling
15	7109-300	Electric connector, 3-prong twist lock	38	-----	Full pressure bypass ball valve
16	2430-804	Vibrator control angle valve, 1/4"	38	8710-40007A	Blast pressure gauge, 0-160 psi
17	8710-92301S	Tri-Clamp, 1-1/2"	39	-----	Pressure vessel nameplate
18	8720-000-02	Automatic air valve 1"	40	2100-011	Popup Gasket
19	2014-300	Breather vent, 1/8"	41	2100-010	Popup Head
20	2423-906	Gate valve, blast pressure control	42	5010-010	Lid, 12"
21	2401-506	Cleanout ball valve, 1" (TVII)	43	5011-010	Screen, 12" (1/4" mesh)
22	7109-301	Electric plug, 3-prong twist lock	44	2013-402	Dust eliminator, 1/4" mmpt
23	7109-300	Electric connector, 3-prong twist lock	45	7046-003	Wheel & Tire
24	4224-710-02	Water quick connect plug, 1/4"		7019-519	Nylock Nut 3/4"
25	4213-XXX	Blast hose coupling			
26	7074-055	Deadman extension cord, 55ft.			
27	7072-012	Power cord (12vdc)			

9.2(c) M21/M31 Abrasive Blaster with Electric Control System

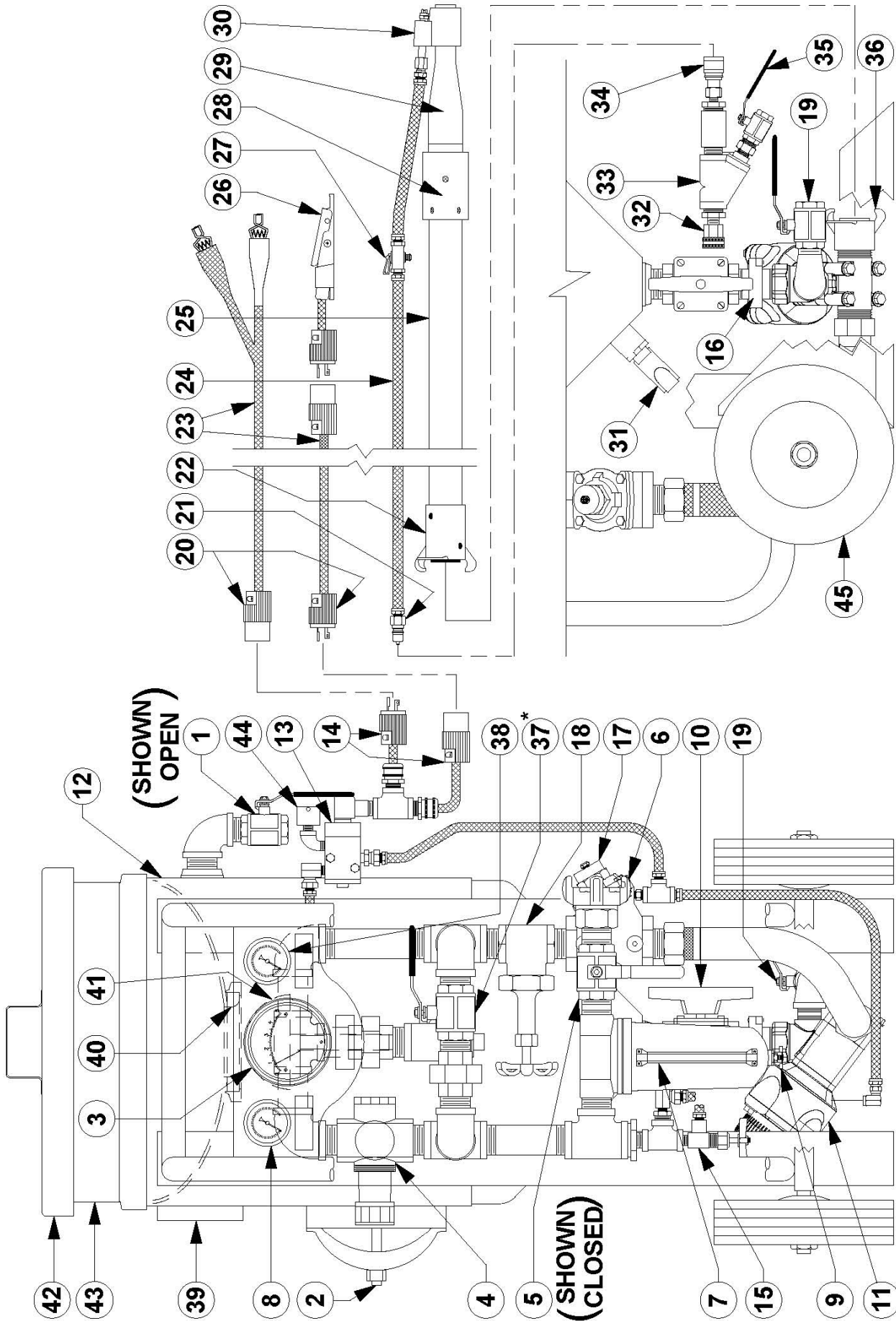

9.2(d) M21/M31 Abrasive Blaster Electric Control Parts List

ITEM	PART NUMBER	DESCRIPTION	ITEM	PART NUMBER	DESCRIPTION
1	2401-504	Blowdown ball valve 1/2"	24	4101-002	Water hose, 1/4" push on
2	7000-001-11	Handway crab assembly, 6" x 8"	25	4104-XXX-XX	Blast hose assembly
3	2010-013	Differential Pressure Gauge, 0-5 psi	26	2263-400-01	Deadman switch w/plug
*4	2003-007	Air pressure regulator	27	2024-001	Petcock valve, 1/4"F x 1/4"F
*5	2401-507	Air inlet ball valve	28	4215-XXX	Nozzle holder
*6	4211-107	Crowfoot, 4-lug	29	5000-XXX	Blast nozzle
*7	2302-207-50	Air filter, 50 micron	30	8020-000-02	Wet blast attachment assembly
8	8710-40007A	Tank pressure gauge, 0-160 psi	31	2020-025	Vibrator
9	-----	Drain valve for air filter	32	4227-304-05	Garden hose coupling
10	8710-36101	Media Valve Shut-off, 1-1/4"	33	4227-305-99	Garden hose gasket, 3/4"
*11	2152-217	Thompson Valve II® w/slotted sleeve	34	2300-305-02	Y-strainer, 60 mesh 3/4"
12	8720-021-01	Blast pot, M Series Model M21	35	4224-711-02	Water quick connect socket, 1/4"
	8720-031-01	Blast pot, M Series Model M31	36	2401-502	Drain ball valve, 1/4"
13	See Section 9.6	Control valve, electric	37	4214-107-01	Threaded coupling
14	7109-301	Electric plug, 3-prong twist lock	38	2401-507	Full pressure bypass ball valve
	7109-300	Electric connector, 3-prong twist lock	39	8710-40007A	Blast pressure gauge, 0-160 psi
15	2430-804	Vibrator control angle valve, 1/4"	40	-----	Pressure vessel nameplate
16	8710-92301S	Tri-Clamp, 1-1/2"	41	2100-011	Popup gasket
17	2123-107	Automatic air valve	42	2100-010	Popup head
	2014-300	Breather vent, 1/8"	43	5010-060	Lid, 24"
18	2423-907	Gate valve, blast pressure control	44	5011-060	Screen, 24" (1/4" mesh)
19	2401-506	Cleanout ball valve, 1" (TVII)	45	2013-402	Dust eliminator, 1/4" mmpt
20	7109-301	Electric plug, 3-prong twist lock		7046-003	Wheel & Tire
	7109-300	Electric connector, 3-prong twist lock		7019-519	Nylock Nut 3/4"
21	4224-710-02	Water quick connect plug, 1/4"			
22	4213-XXX	Blast hose coupling			
23	7074-055	Deadman extension cord, 55ft.			
	7072-012	Power cord (12vdc)			

9.3(a) Remote Abrasive Cutoff (Pneumatic)

No.	Part No.	Description
1	2025-010	Abrasive Cutoff Switch
	2025-100-01	Toggle Switch Guard
	2014-300	Breather Vent, Brass 1/8"
	3031-300-00	Hex Nipple 1/8" x 1/8"
2	4204-301-00	Hose Insert, Rigid 3/16" x 1/8" Brass
3	3011-100	Tee, Galv 1/8"
4	4201-500-00	Strait Swivel, 1/8"M x 1/8"F
5	4203-500-00	Swivel 90, 1/8"M x 1/8"F
6	2229-000	Control Valve, pneumatic
7	3029-102-09	Nipple TBE, Galv. 1/4" x 2"
	3000-102	Elbow 90°, Galv. 1/4"
	2013-402	Dust Eliminator 1/4" MNPT
8	4203-502-02	Swivel 90°, 1/4"M x 1/4"F
9	4201-502-02	Strait Swivel, 1/4"M x 1/4"F
10	4200-302-02	Push-On Hose Insert 1/4" x 1/4"
11	4204-301-02	Hose Insert, Rigid 3/16" x 1/4" Brass
12	4224-301-02	Q. Connect SSO/BR Socket 1/4"
13	4224-300-02	Q. Connect SSO/AL Plug 1/4"
	3031-302-00	Hex Nipple 1/8" x 1/4"
14	7035-301	Ferrules, Brass .525
15	4100-001-10	Hose, Twinline 3/16" (Green)
16	4101-002	Hose, Push-on 1/4"

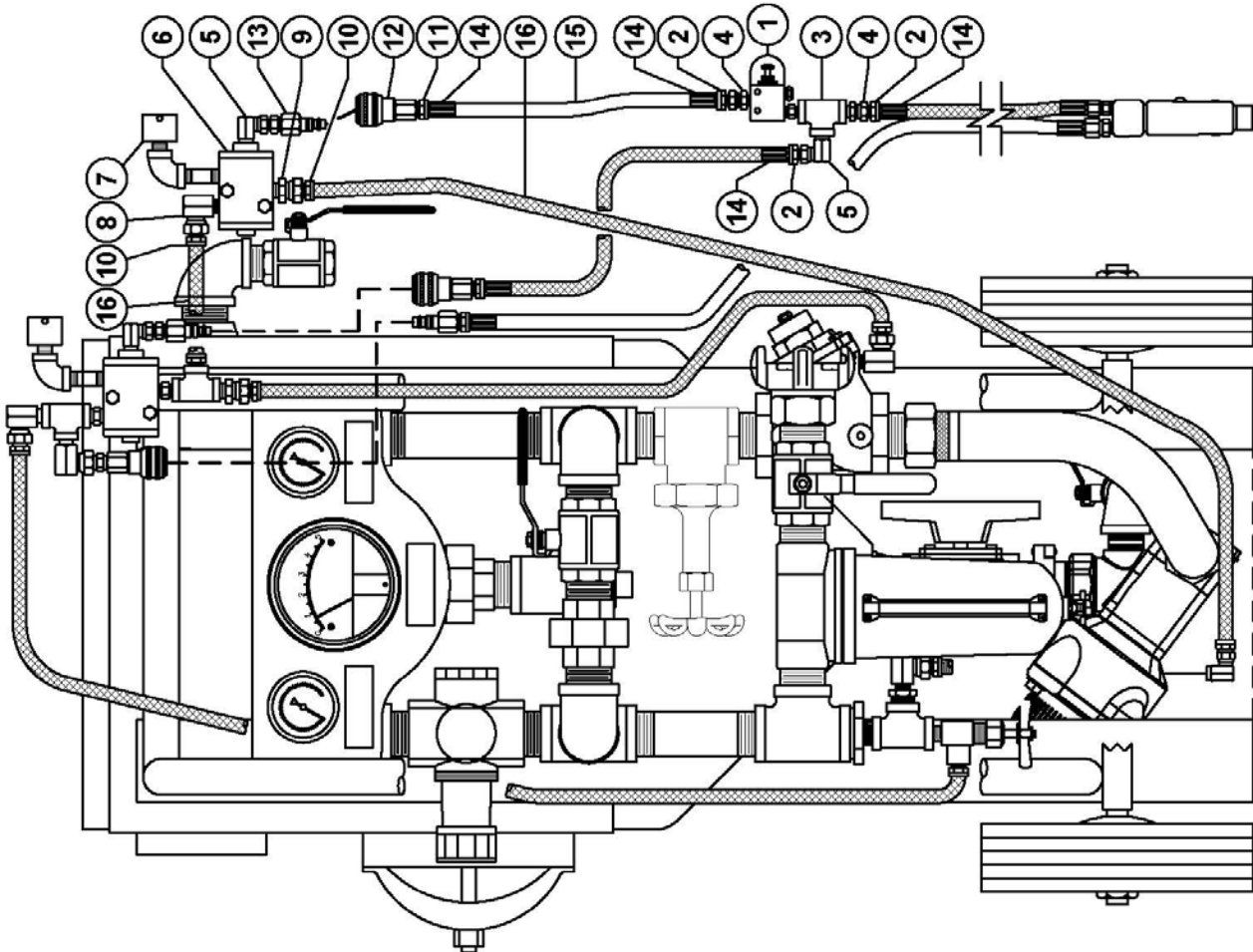

9.3(b) Remote Abrasive Cutoff (Electric)

No.	Part No.	Description
1	2025-100-02	Toggle Switch
	2025-100-01	Toggle Switch Guard
	2025-100-04	Conduit Outlet Body 1/2"
	2025-100-03	Conduit Outlet Body Cover 1/2"
2	7117-504	CGB Connector, 1/2"
3	7106-163	Electric Cord, 16/3 SJ
4	See Section 9.6	Electric Control Valve
5	7100-504-03	Polytube Fitting, 3/8" x 1/2"
6	2013-402	Dust Eliminator 1/4" MNPT
	3000-102	Elbow 90°, Galv 1/4"
	3029-102-09	Nipple TBE, Galv 1/4" x 2"
7	4203-502-02	Swivel 90°, 1/4"M x 1/4"F
8	4200-302-02	Push-On Hose Insert 1/4" x 1/4"
9	4201-502-02	Strait Swivel, 1/4"M x 1/4"F
10	4101-002	Hose, Push-On 1/4"
11	7120-001	Tubing, Polyethylene 3/8"

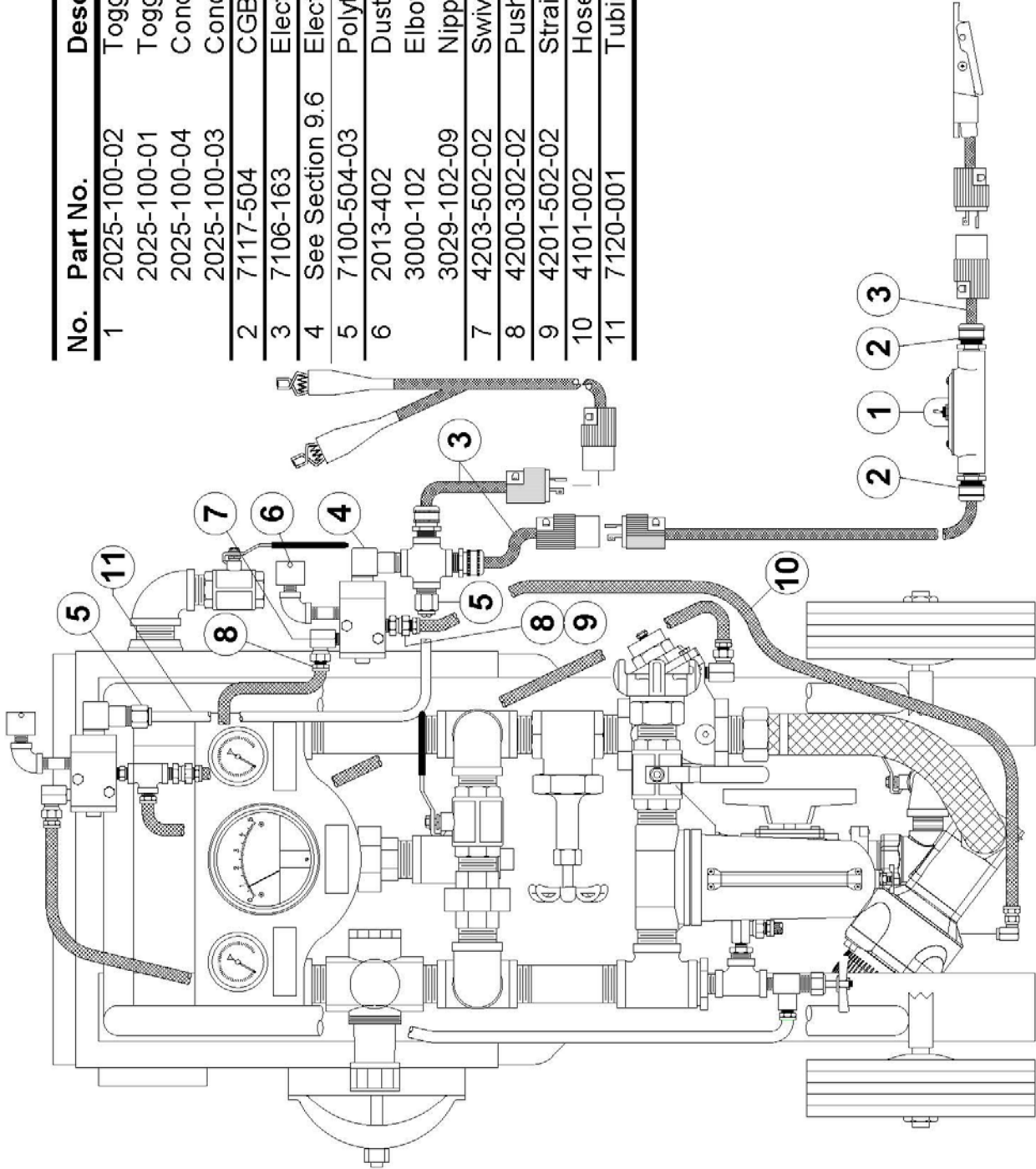

9.3 Thompson Valve® w/ slotted sleeve

	2149-316	1" Valve With T.C. Slotted Sleeve
	2149-317	1 1/4" Valve With T.C. Slotted Sleeve
	2149-318	1 1/2" Valve With T.C. Slotted Sleeve
No.	Part No.	Description
	2149-200-99	Replacement Parts Kit With T.C. Slotted Sleeve
	2149-000-98	Replacement Parts Kit T.C. Seals Only
1.	2149-000-01	Knob
2.	2149-000-02	Cap
3.	2149-000-19	Bump Ring
4.	2149-000-03	Spring
5.	2149-000-08	Nut
6.**	2149-000-04	Piston Seal
7.	2149-000-05	Piston
8.*	2149-000-07	Tungsten Carbide Plunger
9.	2149-300-09	Cylinder With Cleanout
10.**	2149-000-06	Plunger Seal
11.**	2149-200-13	Tungsten Carbide Slotted Sleeve
12.**	2149-000-10	Seat
13.*	2149-000-14	Insert
14.**	2149-000-18	O-Ring
15.	2149-000-25	Vibration Disk
16.	2149-300-11	Base With Cleanout
17.	7010-507-55	Bolt
18.	2149-006-15	Pipe Nipple, 1" x 8"
	2149-007-15	Pipe Nipple, 1 1/4" x 8"
	2149-008-15	Pipe Nipple, 1 1/2" x 8"

* Included In Tungsten Carbide Replacement Parts Kit

+ Included In Tungsten Carbide Replacement Seals Kit

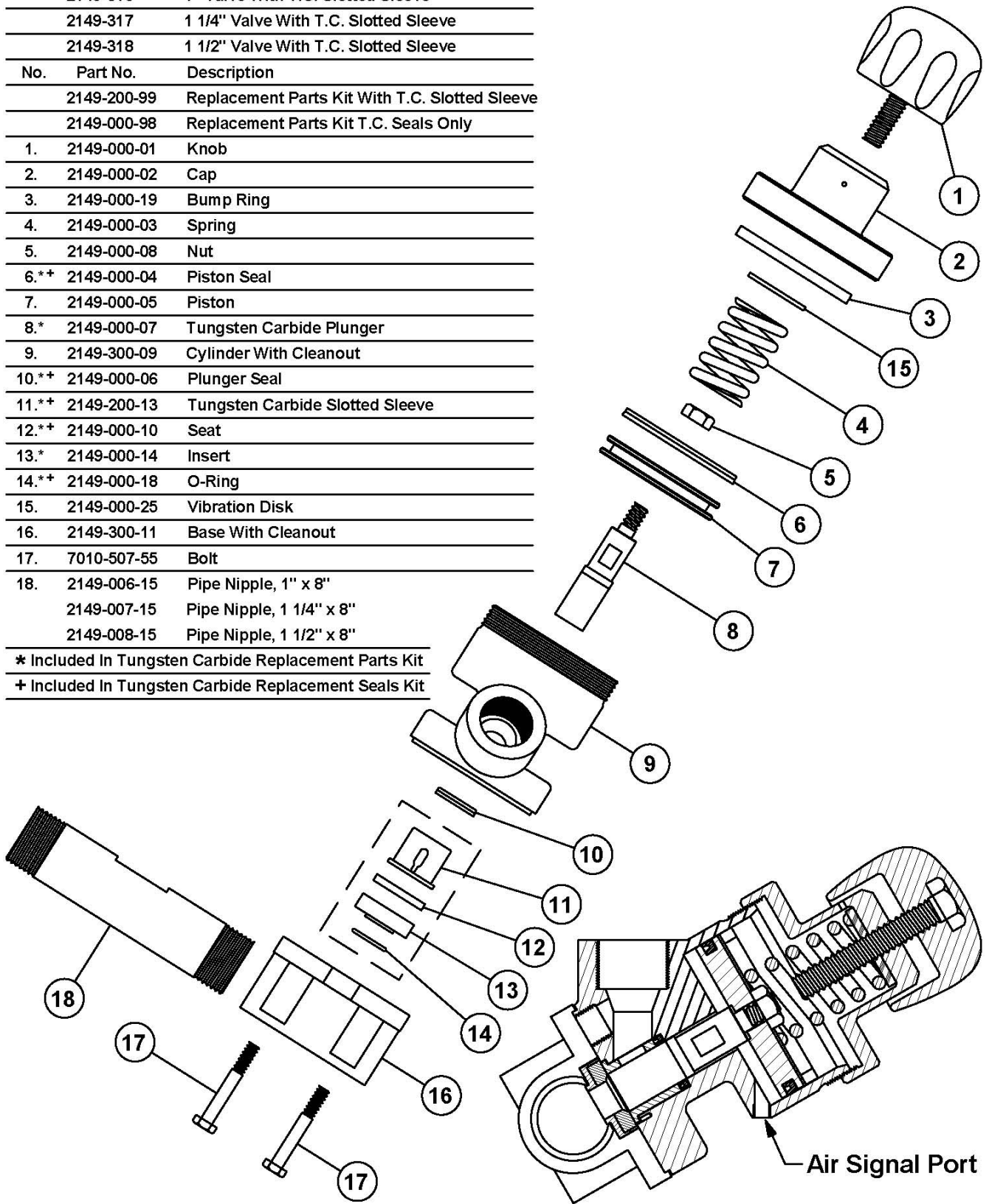

9.4 Thompson Valve® II w/ slotted sleeve

	2152-216	1" Valve With Slotted Sleeve
	2152-217	1 1/4" Valve With Slotted Sleeve
	2152-218	1 1/2" Valve With Slotted Sleeve
No.	Part No.	Description
	2152-200-99	Replacement Parts Kit With Slotted Sleeve
	2152-000-98	Replacement Parts Kit Seals Only
1.	2152-000-01	Knob
2.	2152-000-17	Breather Vent
3.	2152-000-12	Spring Retainer
4.**	2152-000-18	O-Ring
5.	7027-503-02	Washer
6.	7010-507-07	Hex Bolt, 3/8" UNC x 1-1/4" Lg.
7.	2152-000-02	Cap Plate
8.**	2152-000-16	Cap Gasket
9.	2149-000-19	Deleted
10.	2152-000-25	Vibration Disc
11.	2152-000-03	Spring
12.	2149-000-08	Nut
13.**	2149-000-04	Piston Seal
14.	2152-000-05	Piston
15.*	2152-000-07	Tungsten Carbide Plunger
16.	2152-000-09	Cylinder
17.**	2149-500-06	Plunger Seal (Molythane)
18.**	2152-000-06	Plunger Seal (Urethane)
19.	2152-000-14	Body
20.	2152-000-19	Base, 1" NPT
	2152-000-15	Base, 1 1/4" NPT
	2152-000-11	Base, 1 1/2" NPT
21.	7010-507-95	Hex Bolt, 3/8" UNC x 4 3/4" Lg.
22.	3014-106	Plug
23.**	2152-000-21	O-Ring
24.*	2152-200-13	Tungsten Carbide Slotted Sleeve
25.**	2152-000-10	Seat
26.	8403-000-54	Cleanout Ball Valve Adder
27.	3006-106	Street Elbow 90°, 1" Galv.
28.	3029-106-09	Nipple TBE, 1" x 2" Lg. Galv.
29.	2401-506	Ball Valve, 1" Full Port

*Included In Tungsten Carbide Replacement Parts Kit
 **Included In Tungsten Carbide Replacement Seals Kit

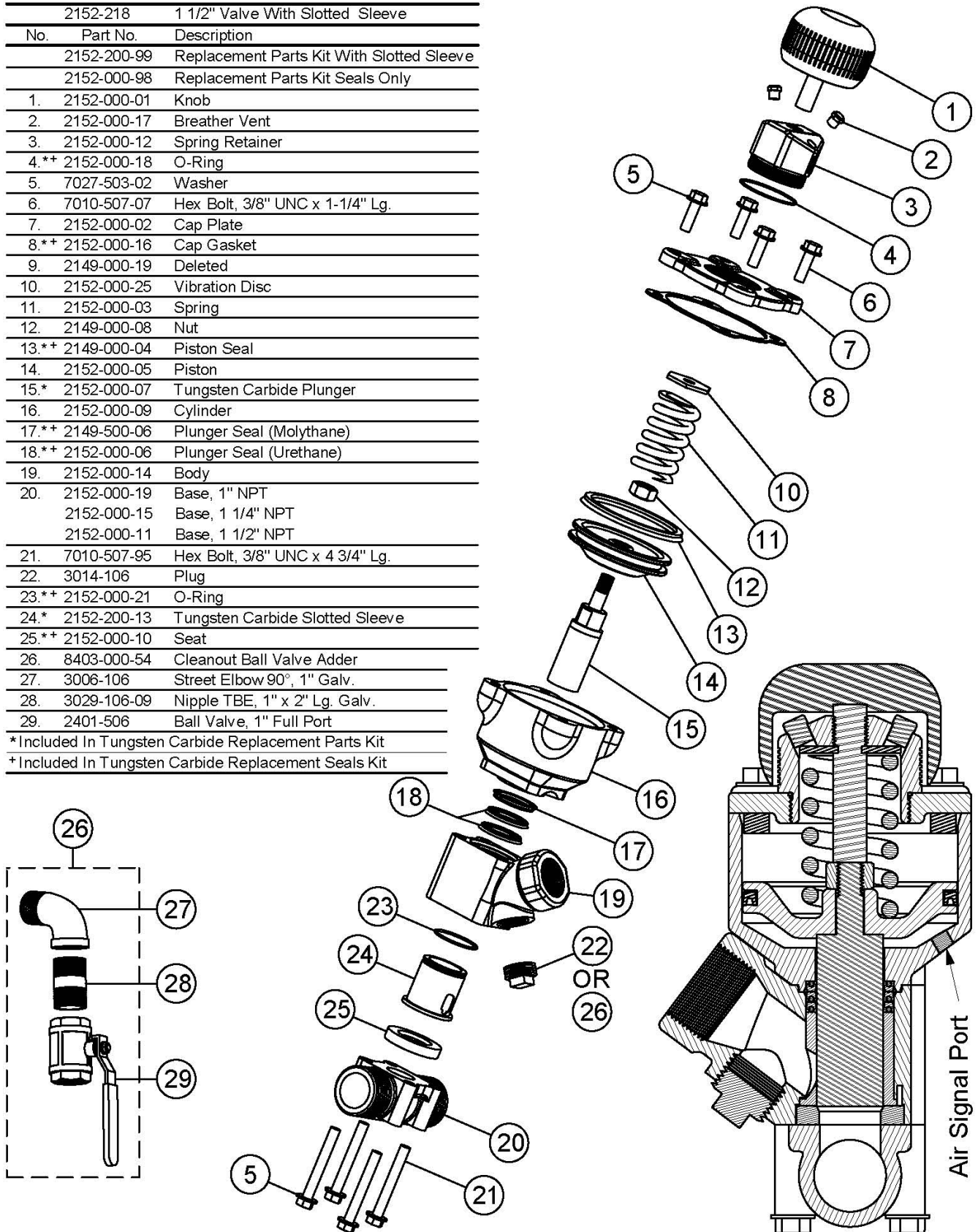

9.6 Control Valves (pneumatic and electric)

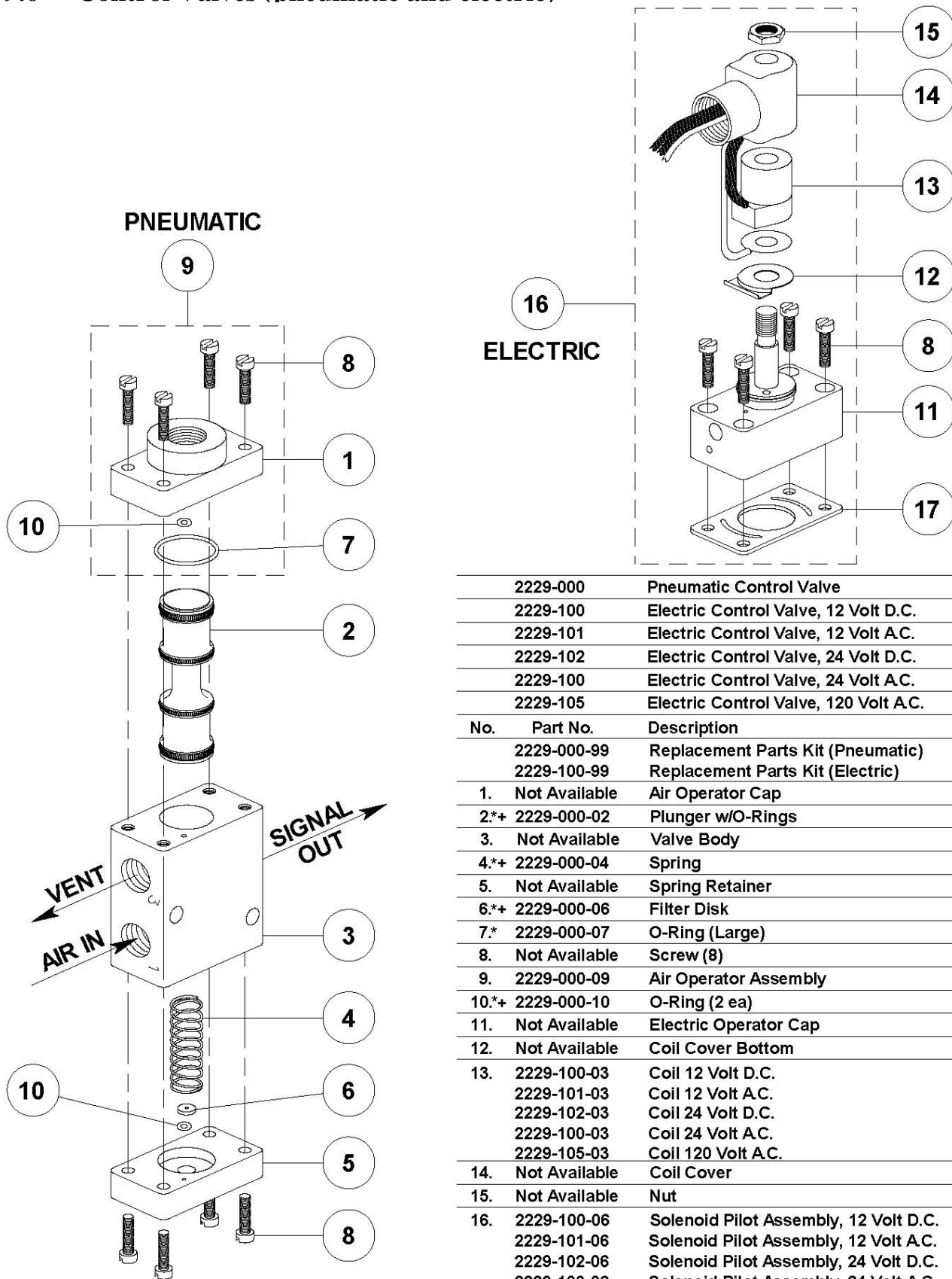

	2229-000	Pneumatic Control Valve
	2229-100	Electric Control Valve, 12 Volt D.C.
	2229-101	Electric Control Valve, 12 Volt A.C.
	2229-102	Electric Control Valve, 24 Volt D.C.
	2229-100	Electric Control Valve, 24 Volt A.C.
	2229-105	Electric Control Valve, 120 Volt A.C.
No.	Part No.	Description
	2229-000-99	Replacement Parts Kit (Pneumatic)
	2229-100-99	Replacement Parts Kit (Electric)
1.	Not Available	Air Operator Cap
2.*+	2229-000-02	Plunger w/O-Rings
3.	Not Available	Valve Body
4.*+	2229-000-04	Spring
5.	Not Available	Spring Retainer
6.*+	2229-000-06	Filter Disk
7.*	2229-000-07	O-Ring (Large)
8.	Not Available	Screw (8)
9.	2229-000-09	Air Operator Assembly
10.*+	2229-000-10	O-Ring (2 ea)
11.	Not Available	Electric Operator Cap
12.	Not Available	Coil Cover Bottom
13.	2229-100-03	Coil 12 Volt D.C.
	2229-101-03	Coil 12 Volt A.C.
	2229-102-03	Coil 24 Volt D.C.
	2229-100-03	Coil 24 Volt A.C.
	2229-105-03	Coil 120 Volt A.C.
14.	Not Available	Coil Cover
15.	Not Available	Nut
16.	2229-100-06	Solenoid Pilot Assembly, 12 Volt D.C.
	2229-101-06	Solenoid Pilot Assembly, 12 Volt A.C.
	2229-102-06	Solenoid Pilot Assembly, 24 Volt D.C.
	2229-100-06	Solenoid Pilot Assembly, 24 Volt A.C.
	2229-105-06	Solenoid Pilot Assembly, 120 Volt A.C.
17. +	2229-100-07	Gasket (Electric Only)
* Included In replacement parts kit-pneumatic		
+ Included In replacement parts kit-electric		

9.7 Automatic Air Valve (normally closed)

2123-106 1" Valve		
No.	Part No.	Description
	2123-006-99	Replacement Parts Kit
1.*	2123-006-01	Gasket
2.*	2123-006-02	Diaphragm
3.*	2123-006-03	O-ring
4.	2123-006-04	Retainer Bushing
5.*	2123-006-05	O-ring
6.	2123-006-06	Disk Retainer
7.*	2123-006-07	O-ring
8.	2123-006-08	Seat
9.	2123-006-09	Disc Plate
10.	"Deleted"	Lock Washer, Internal
11.*	2123-006-11	Lock Nut
12.	2123-106-12	Cap
13.*	2123-006-13	Hex Nut (w/thread lock)
14.	2123-006-14	Cap Screw
15.	2123-006-15	Diaphragm Plate
17.	2123-006-17	Lock Nut
18.	2123-006-18	Body, 1"
19.	2123-006-19	Shaft
20.*	2123-006-20	Gasket
21.*	2123-006-21	Disc
22.	2123-106-22	O-ring
23.	2123-106-23	Spring Retainer
24.	2123-106-24	Spring
25.	2014-300	Vent, 1/8"(not included)

* Included In Replacement Parts Kit

2123-107 1 1/4" Valve		
No.	Part No.	Description
	2123-007-99	Replacement Parts Kit
1.*	2123-007-01	Gasket
2.*	2123-007-02	Diaphragm
3.*	2123-007-03	O-ring
4.	2123-007-04	Retainer Bushing
5.*	2123-007-05	O-ring
6.	2123-007-06	Disk Retainer
7.*	2123-007-07	O-ring
8.	2123-007-08	Seat
9.	2123-007-09	Disc Plate
10.	"Deleted"	Lock Washer, Internal
11.*	2123-007-11	Lock Nut
12.	2123-107-12	Cap
13.*	2123-007-13	Hex Nut (w/thread lock)
14.	2123-007-14	Cap Screw
15.	2123-007-15	Diaphragm Plate
17.	2123-007-17	Lock Nut
18.	2123-007-18	Body, 1 1/4"
	2123-008-18	Body, 1 1/2"
19.	2123-007-19	Shaft
20.*	2123-007-20	Gasket
21.*	2123-007-21	Disc
22.	2123-107-22	O-ring
23.	2123-107-23	Spring Retainer
24.	2123-107-24	Spring
25.	2014-300	Vent, 1/8"(not included)

* Included In Replacement Parts Kit

2123-109 2" Valve		
No.	Part No.	Description
	2123-009-99	Replacement Parts Kit
1.*	2123-009-01	Gasket
2.*	2123-009-02	Diaphragm
3.*	2123-009-03	O-ring
4.	2123-009-04	Retainer Bushing
5.*	2123-009-05	O-ring
6.	2123-009-06	Disk Retainer
7.*	2123-009-07	O-ring
8.	2123-009-08	Seat
9.	2123-009-09	Disc Plate
10.	"Deleted"	Lock Washer, Internal
11.*	2123-009-11	Lock Nut
12.	2123-109-12	Cap
13.*	2123-009-13	Hex Nut (w/thread lock)
14.	2123-009-14	Cap Screw
15.	2123-009-15	Diaphragm Plate
17.	2123-009-17	Lock Nut
18.	2123-009-18	Body, 2"
19.	2123-009-19	Shaft
20.*	2123-009-20	Gasket
21.*	2123-009-21	Disc
22.		Not Needed
23.	2123-109-23	Spring Retainer
24.	2123-109-24	Spring
25.	2014-300	Vent, 1/8"(not included)

* Included In Replacement Parts Kit

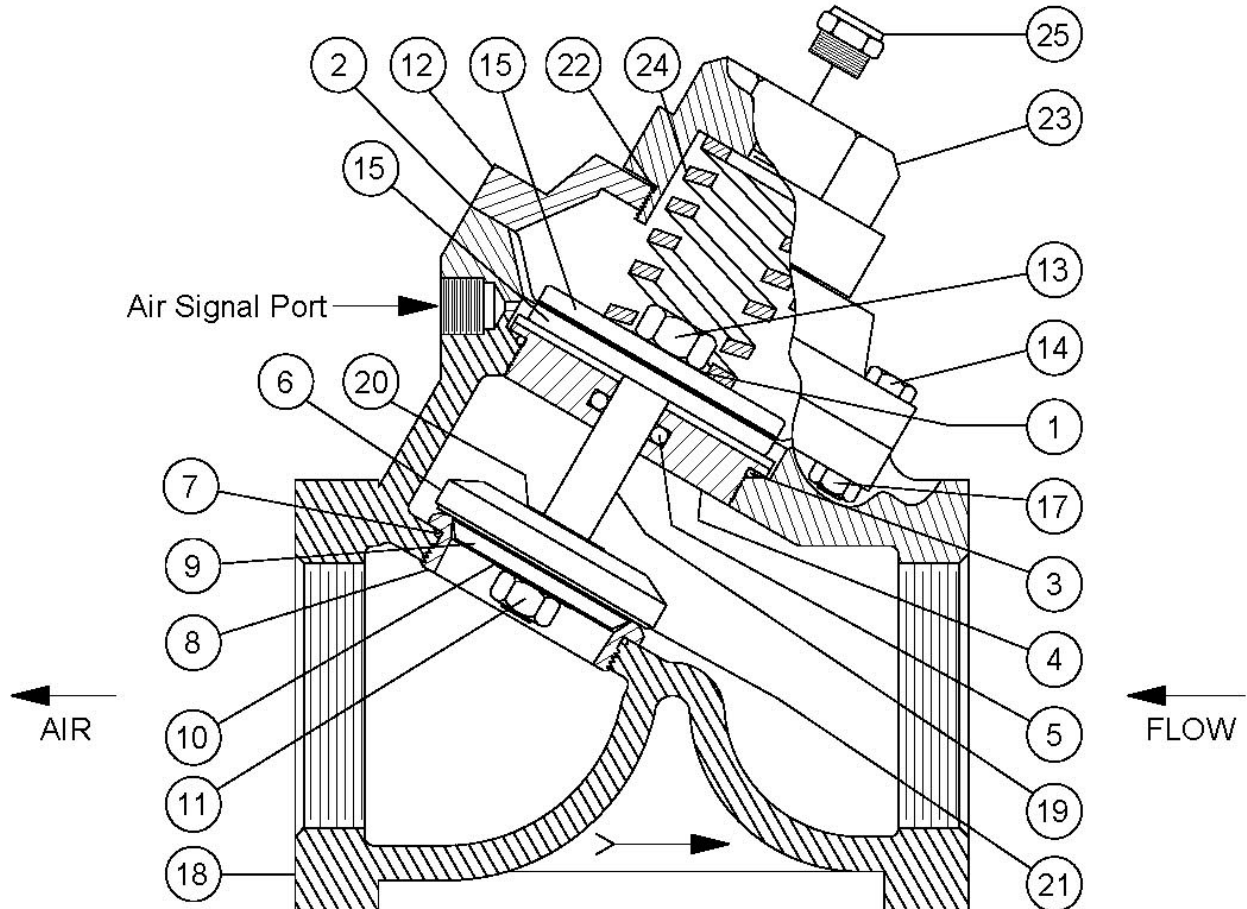

NOTE: With spring closed valve air flow is in opposite direction from arrow on valve body.

9.8(a) G2 Pneumatic Deadman

Item	Part No.	Description
	2263-002	G2 Pneumatic Deadman
	2263-002-99	G2 Replacement Parts Kit
1.	2263-002-01	G2 Deadman Lever
2.	2263-002-02	G2 Deadman Body
*3.	2263-002-03	G2 Deadman Cartridge Assembly
4.	2263-002-04	G2 Deadman Hinge Pin
*5.	2263-002-05	G2 Deadman Cartridge Set Screw
6.	2263-002-06	G2 Deadman Button
*7.	2263-002-07	Deadman Spring
*8.	2263-000-08	Deadman Screw For Button
9.	3031-300-00	Hex Nipple, 1/8" x 1/8" With Ball Seat
10.	3031-302-02	Hex Nipple, 1/4" x 1/4" With Ball Seat

*Items included in Replacement Parts Kit

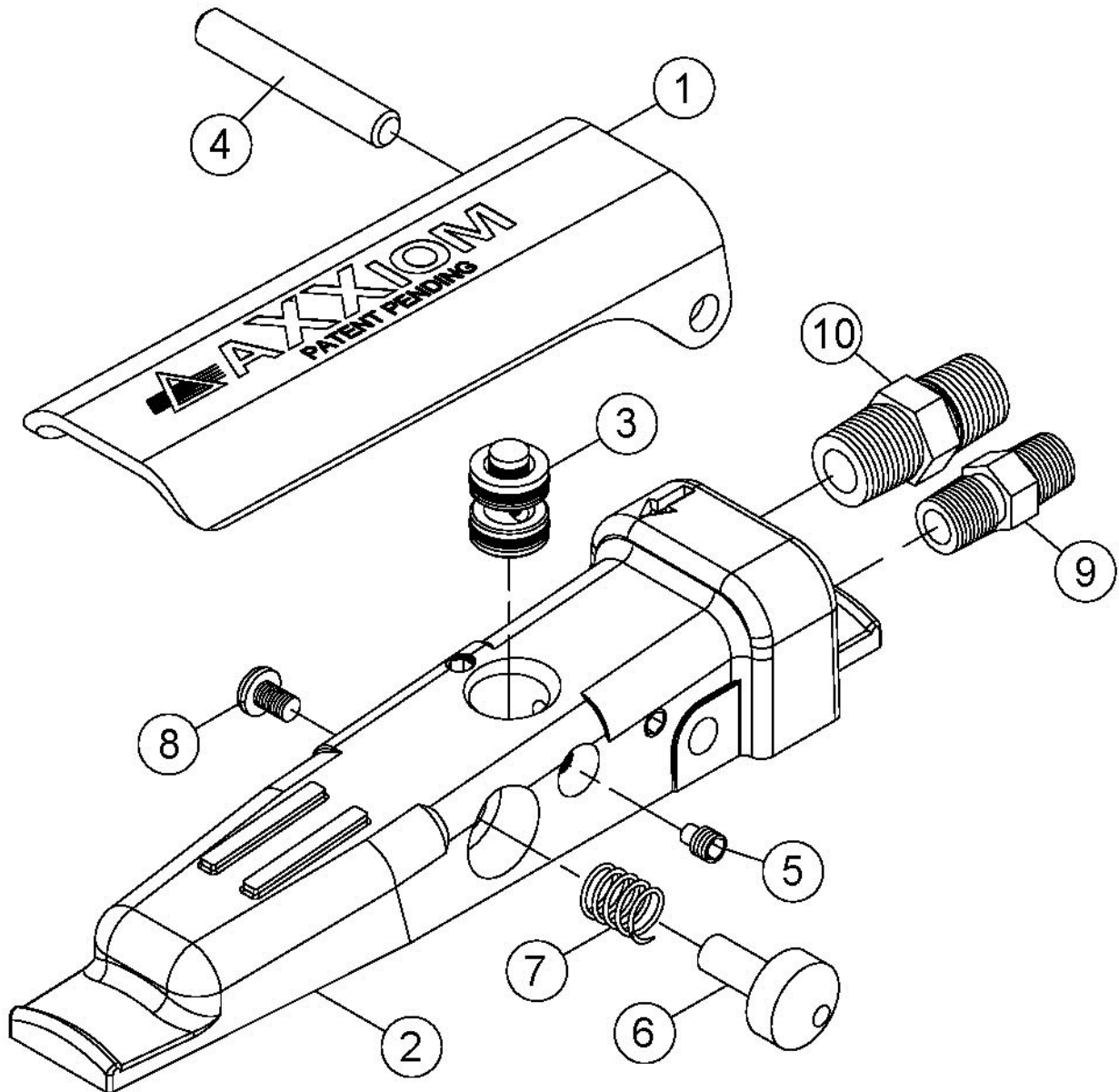

9.8 (b) Deadman Valves (Pneumatic)

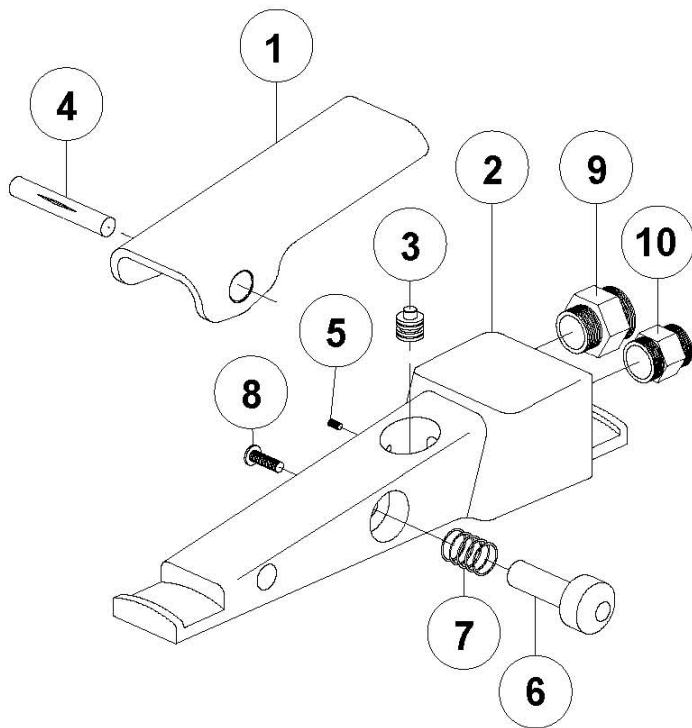

No.	Part No.	Description
	2263-000	Pneumatic Deadman
	2263-000-99	Replacement Parts Kit
1.	2263-000-01	Lever
2.	2263-000-02	Body
*3.	2263-000-03	Cartridge
4.	2263-000-04	Hinge Pin
*5.	2263-000-05	Set Screw
6.	2263-000-06	Safety Button
*7.	2263-000-07	Spring
*8.	2263-000-08	Screw for Button
9.	3031-302-00	Hex Nipple, 1/8" x 1/4"
10.	3031-300-00	Hex Nipple, 1/8" x 1/8"
* Included in replacement parts kit		

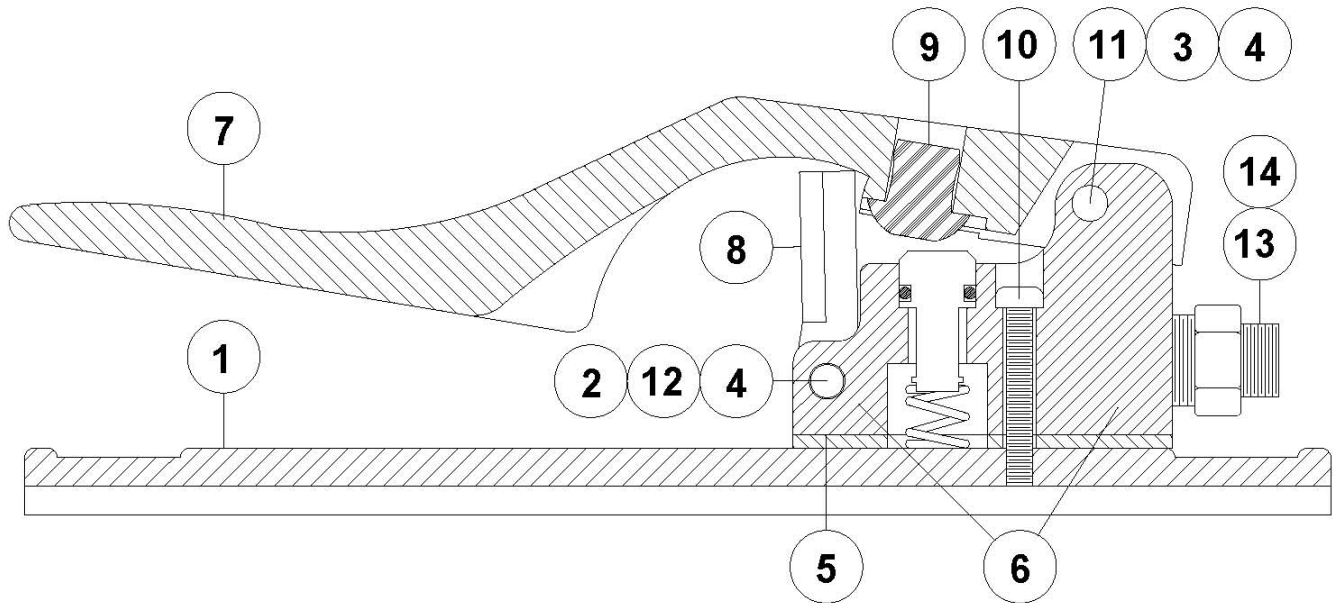

2263-001			Pneumatic Deadman II		
No.	Part No.	Description	No.	Part No.	Description
	2263-001-99	Replacement Parts Kit Level I	8. +	2263-001-08	Safety Flap
	2263-001-98	Replacement Parts Kit Level II	9.**	2263-001-09	Plunger Plug
1.	2263-001-01	Base	10.	2263-001-10	Body Mounting Screw
2. +	2263-001-02	Safety Flap Spring	11.	2263-001-11	Lever Spring
3. +	2263-001-03	Lever Hinge Screw	12. +	2263-001-12	Flap Hinge Screw
4.	2263-001-04	Hinge Pin Nut	13.	3031-302-00	Hex Nipple, 1/8" x 1/4"
5.**	2263-001-05	Body Gasket	14.	3031-300-00	Hex Nipple, 1/8" x 1/8"
6.**	2263-001-06	Valve Body Assembly	* Included in replacement parts kit, Level I		
7.	2263-001-07	Lever	+ Included in replacement parts kit, Level II		

9.9 Deadman Switches (Electric)

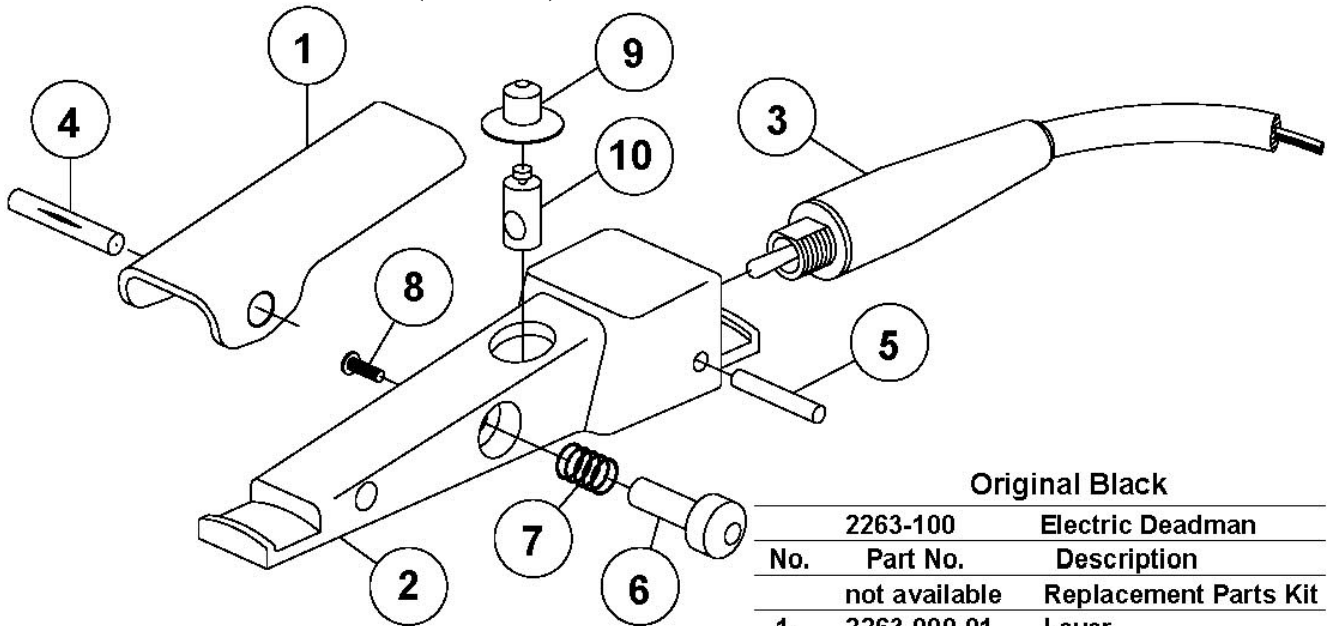

Original Black

No.	Part No.	Description
	2263-100	Electric Deadman
	not available	Replacement Parts Kit
1.	2263-000-01	Lever
2.	not available	Body
3.	not available	Switch
4.	2263-000-04	Hinge Pin
5.	not available	Switch Lock Pin
6.	2263-000-06	Safety Button
7.	2263-000-07	Spring
8.	2263-000-08	Screw for Button
9.	not available	Dust Cover
10.	not available	Plunger

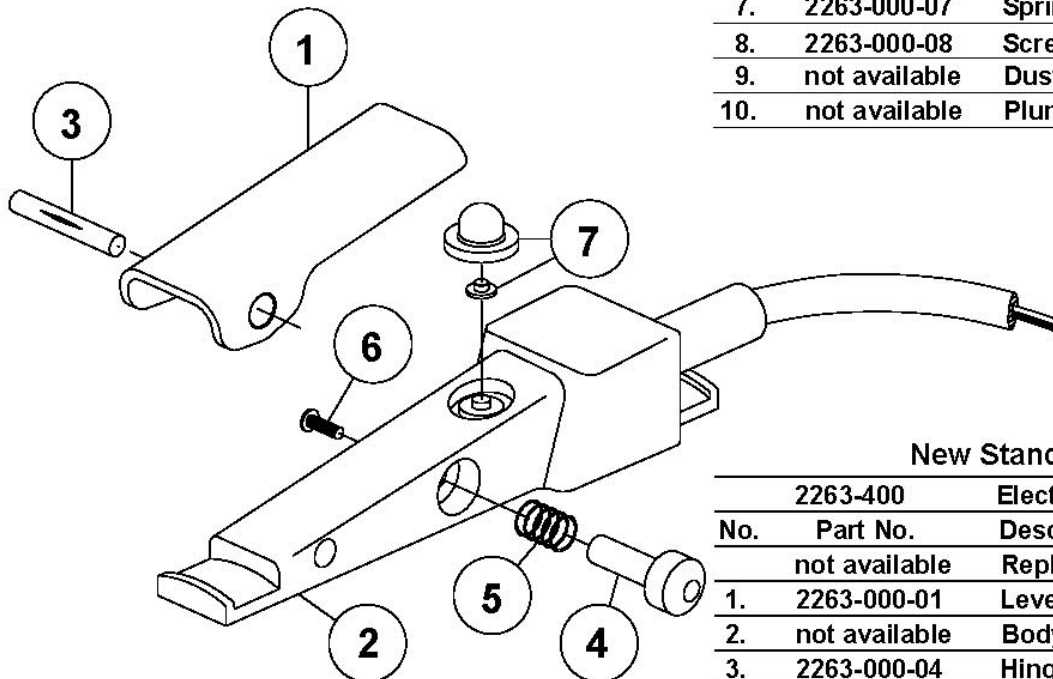

New Standard

No.	Part No.	Description
	2263-400	Electric Deadman
	not available	Replacement Parts Kit
1.	2263-000-01	Lever
2.	not available	Body w/Molded Switch
3.	2263-000-04	Hinge Pin
4.	2263-000-06	Safety Button
5.	2263-000-07	Spring
6.	2263-000-08	Screw for Button
7.	2263-400-09	Dust Cover w/Insert

10.0 Recommended Spare Parts Lists

A) ELECTRIC and PNEUMATIC CONTROLS (see note below & refer to Section 9.0 drawings)

QTY	PART #	DESCRIPTION
1	2123-00X-02	Auto Air Valve Diaphragm (specify piping size)
1	2123-00X-99	Auto Air Valve Replacement Part Kit (specify piping size)
1	2123-10X	Auto Air Valve (specify piping size)
1	2123-10X-24	Auto Air Valve Spring (specify piping size)
1	2152-000-03	Thompson Valve® II Spring
1	2152-000-09	Thompson Valve II Cylinder
1	2152-000-XX	Thompson Valve II Base (specify piping size)
1	2152-XXX-99	Thompson Valve II Replacement Part Kit (specify sleeve type)
1	2152-XXX	Thompson Valve II (specify piping size and sleeve type)
1	2401-504	Blowdown Ball Valve, 1/2"
1	2401-50X	Air Inlet Ball Valve (specify piping size)
1	42XX-10X	Air Inlet Crowfoot (specify piping size)
10	42XX-999	Crowfoot Gasket (specify piping size)
1	8710-36101	Media Shutoff Valve, 1-1/4"
1	2024-001	Petcock valve, 1/4"
1	8710-92301S	Tri-clamp, 1-1/2" spring loaded
10	8710-98503	Tri-clamp O-ring
1	2100-010	Popup With Stem
1	2100-011	Popup Gasket
2	4214-10X	Blast Hose Coupling (specify size)
10	4214-999	Hose Coupling Gasket
5	4205-10X-99	Insert Gasket (specify piping size)
10	7119-002	Safety Pin, Air/Blast Hose Coupling
2	7000-001-06	Handway Gasket, 6 x 8
1	2014-300	Breather Vent, 1/8"
1	2013-402	Dust Eliminator, 1/4"
1	2003-007-99	Air Regulator Replacement Parts Kit
1	2302-207-99	Air Filter Replacement Parts Seals Kit
1	2302-207-96	Air Filter Replacement Parts Element Kit
1	2302-207-97	Air Filter Replacement Parts Sight Glass Kit
1	2302-204-95	Air Filter Replacement Parts Drain Kit
1	8710-40007A	Pressure Gauge, Panel Mount 0-160psi/bar

B) ITEMS FOR ELECTRIC CONTROLS ONLY (see note below)

QTY	PART #	DESCRIPTION
1	2229-100	Electric Control Valve (12vdc)
2	2229-100-99	Electric Control Valve Replacement Parts Kit
1	2263-400-01	Electric Deadman Switch With Plug
1	7074-055	Extension Cord 55'
1	7109-300	Female Twist-lock Connector, 3-Prong
1	7109-301	Male Twist-lock Plug, 3-Prong

C) ITEMS FOR PNEUMATIC CONTROLS ONLY (see note below)

1	2229-000	Pneumatic Control Valve
2	2229-000-99	Pneumatic Control Valve Replacement Parts Kit
1	2263-000	Pneumatic Deadman Valve
2	2263-000-99	Pneumatic Deadman Valve Replacement Parts Kit
1	4100-501	Twinline Hose, 55ft.
1	4224-300-02	Quick Disconnect Plug, 1/4"
1	4224-301-02	Quick Disconnect Socket, 1/4"

NOTE: Determine the type of blast controls on the M Series abrasive blaster (either electric or pneumatic). Then, the required list of spare parts is List "A" plus either List "B" or "C". Example: If your abrasive blaster has pneumatic controls then the recommended spare parts you need are those items included in Lists "A" and "C".

11.0 Troubleshooting

This section lists probable causes of problems that may occur during operation of the abrasive blaster. Not all of the “probable causes” may apply to your particular abrasive blaster. The probable cause may not apply because of the control type and accessories on the abrasive blaster. Refer to Figure 11.1 and the drawings in Section 9.0.

DANGER

The M Series abrasive blaster is a Pressurized Vessel. Propelled objects will cause serious injury or death. Depressurize vessel before performing any maintenance. See Section 6.2.

11.1 Malfunction With Deadman Lever In The “Off” Position

11.1.1. Blast air stops but abrasive will not shut off

- (1) Trash stuck between plunger and seat in Thompson Valve® (#13).
- (2) Defective valve plunger in Thompson Valve (#13).
- (3) Defective sleeve in Thompson Valve (#13).
- (4) Blocked air hose to Thompson Valve (#13).
- (5) Defective spring in Thompson Valve (#13) (check length of spring).
- (6) Thompson Valve cap (or spring retainer) not screwed all the way down (hand tighten only).

11.1.2. Abrasive stops but blast air will not shut off

- (1) Defective spring in automatic air valve (#10).
- (2) Defective seat in automatic air valve (#10).
- (3) Blocked air hose to automatic air valve (#10).
- (4) Defective o-ring in automatic air valve (#10) (around shaft).

11.1.3. Both blast air and abrasive will not shut off

- (1) Control lines to deadman valve (#1) are crossed.
- (2) Non-Schmidt deadman (#1) has been installed.
- (3) Control valve (#12) stuck in the “ON” position.
- (4) Blocked control lines.
- (5) Defective deadman valve (#1). Pneumatic deadman cartridge plunger stuck in the “ON” position (down). Cartridge plunger is visible below deadman handle.

11.1.4. Blast outlet turns on accidentally

- (1) The deadman lever (#1) is worn out.
- (2) The safety button on the deadman is missing. See drawings in Section 9.8 and 9.9.
- (3) A bleeder type deadman valve has been installed. A bleeder type deadman valve *is not safe* because a particle of dirt from the air hose can plug the bleed hole and cause the blast outlet to turn on. See *Warnings and Rules for Safer Operation* in Section 1.0.
- (4) Defective electric deadman switch or electric wiring (check for an electric short).

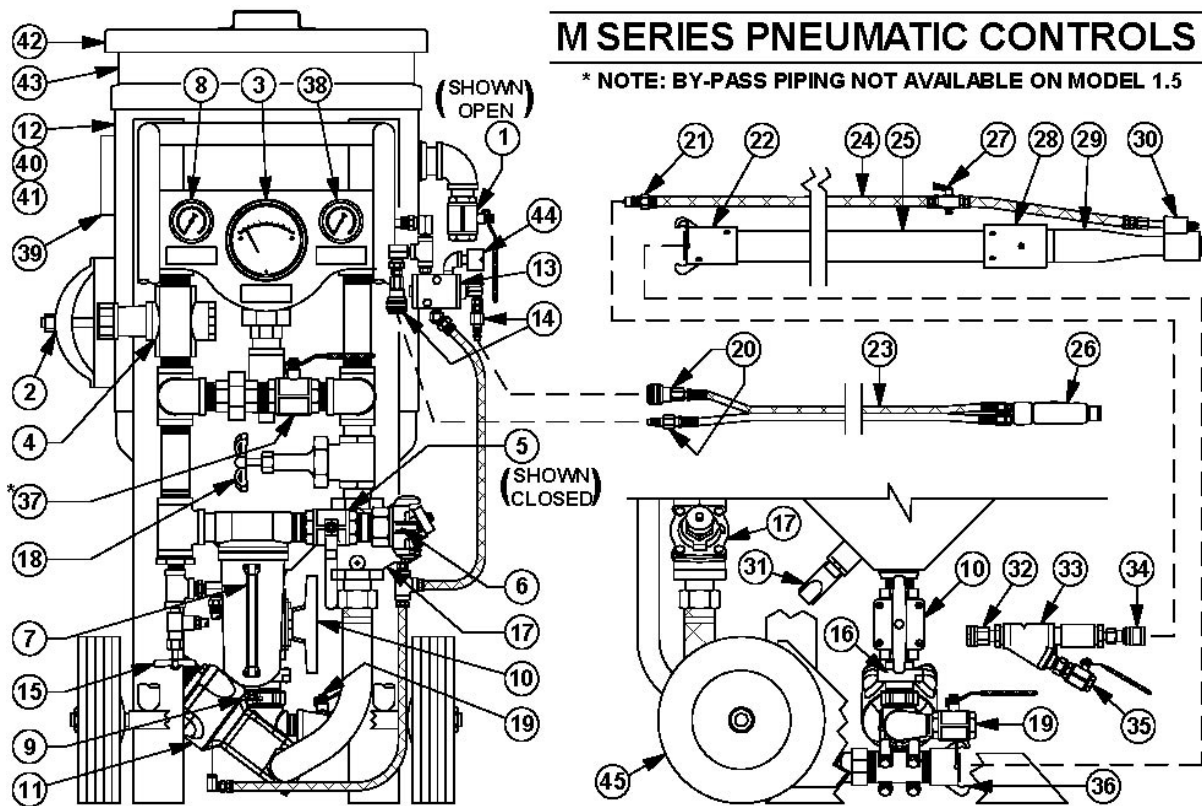

Figure 11.1 – Typical M Series Abrasive Blaster

11.2 Malfunction With Deadman Lever In The “On” Position

11.2.1. Air blasts with no abrasive

- (1) Check abrasive level in the blast vessel even if one outlet continues to blast normally.
- (2) Blocked control hose to Thompson Valve® (#13).
- (3) Thompson Valve plunger stuck in closed position.
- (4) Trash plugging opening from tank to Thompson Valve (#13). See Section 11.3.
- (5) Insufficient air pressure to open Thompson Valve (fully open requires 80 psig).
- (6) Abrasive flow problems. See Section 11.3.
- (7) Defective Thompson Valve piston seal (air will leak from breather).

11.2.2. Abrasive choking out of blast hose with low blast air pressure.

- (1) Thompson Valve abrasive adjustment knob (#20) is open too far.
- (2) Control hose to automatic air valve (#10) is blocked.
- (3) Choke valve (#9) is partially closed.
- (4) Low air compressor output cfm (unit may cycle on and off). See Section 5.0.

11.2.3. Reduced Pressure At The Nozzle (with or without abrasive flow)

- (1) Low air compressor output cfm. See Section 5.0 for air requirements.
- (2) Air hose too small.
- (3) Thompson Valve abrasive adjustment knob (#20) is open too far.
- (4) Check for leaks in blast vessel or control piping.
- (5) Choke valve (#9) is partially closed.
- (6) Trash may be partially plugging the nozzle orifice (#21).

11.2.4. Blast is slow to turn on or will not turn on when deadman lever is pressed down.

- (1) Check quick couplings (#17) on control hoses to see if they are connected properly.
- (2) Control valve (#12) stuck in exhaust position.
- (3) 1/4" strainer (#3) blocked.
- (4) Control hoses blocked.
- (5) Cartridge in deadman valve (#1) is blocked.
- (6) Low air compressor output cfm (unit may cycle on and off). See Section 5.0.
- (7) Air leaks in control hose from the deadman valve (#1) to control valve (#12).
- (8) Trash blocking nozzle orifice.

11.3 Notes on Abrasive Flow Problems

11.3.1. Thompson Valve® operation

If abrasive flow is a problem, remember; the Thompson Valve only opens and closes. The total travel to full open is approximately 3/4 of an inch. This can be quickly checked with the adjustment knob on the abrasive valve.

For this procedure manually close the choke valve (#9) and the media shut-off valve (#24) to prevent blasting. This test is to verify that the Thompson Valve is opening.

With the deadman off, screw the Thompson Valve knob down until it stops. Notice that the knob turns easily when the deadman is off. Next, back the knob out 3/4 of an inch or slightly less, then press the deadman lever down to open the Thompson Valve. The knob should get tight or more difficult to turn because the valve has opened against the adjustment. This guarantees that the valve is fully open. If the material will not flow with the valve fully open, you have an abrasive flow problem, not a problem with the Thompson Valve. The abrasive may be wet, or there may be trash blocking the opening. Try choking the blast outlet to clear the opening. Proceed to step 11.3.2. If the knob does not get tighter during this test troubleshoot the controls and the Thompson Valve piston seal.



Do Not hammer on any part of the pressure vessel to improve abrasive flow. This will cause cracks that may lead to pressure vessel rupture.

11.3.2. Choking the blast outlet

The choke valve (#9) is used to clear any trash that may get into the blast vessel and block the Thompson Valve orifice. Whenever trash (paint chip, cigarette butt, etc.) blocks the Thompson Valve orifice, the procedure is to fully open the Thompson Valve knob, then press down the deadman lever (#1) to begin blasting. While blasting, have an assistant close the choke valve completely for about one second. This creates differential pressure at the Thompson Valve (high pressure above; low pressure below). The higher pressure from the blast vessel should be enough to loosen the trash blocking the Thompson Valve orifice and blast it through the blast nozzle (#21). To prevent excess wear of the Thompson Valve keep the choke valve fully open during normal blasting. If the blaster is equipped with the abrasive cut-off feature set the valve (or switch) to the on-position for the choke procedure. See Section 9.11 and 9.12.

Note: The Thompson Valve II has a cleanout port to use for this procedure. See the Thompson Valve II drawing in Section 9.5 (Item 27).

11.3.3. Blast control hoses

Remember, the blaster controls and valves are normally closed. Therefore, the control hoses are depressurized to turn the blast off and pressurized to turn the blast on. If a needle gauge is available, it is the quickest way to check to see if there is pressure or not. If no needle gauge is available, disconnect each control hose fitting one at a time until the problem is located.

12.0 Warranty and Reference Information

12.1 Warranty

This following section is to be used as a guide in determining warranty policies and procedures for SCHMIDT® products. It is to be used in determining whether a warranty is justified and as a procedural guide in completing a SCHMIDT warranty claim.

12.2 Warranty Policy

1. All SCHMIDT products are guaranteed to be free of defects in material and workmanship at time of shipment. Axxiom Manufacturing, Inc. warrants its products against defects in material and workmanship under normal and proper use for a period of ninety (90) days from the date of delivery. Such warranty is extended only to the buyer who purchases the equipment directly from Axxiom Manufacturing, Inc. or its authorized distributors. This warranty does not include expendable parts such as, but not limited to, hoses, nozzles, and seals.
2. The obligation under this warranty is strictly limited to the replacement or repair, at Axxiom's option, of machines and does not include the cost of transportation, loss of operating time, or normal maintenance services. Axxiom Manufacturing, Inc. shall have no liability for labor, consequential damages, freight or special charges.
3. This warranty does not apply to failure occurring due to abuse, misuse, negligence, corrosion, erosion, normal wear and tear, alterations or modifications made to the machine without express written consent of Axxiom Manufacturing, Inc.
4. Warranty requests must be submitted in writing within thirty (30) days after failure.
5. Written authorization to return merchandise under warranty must first be obtained from Axxiom Manufacturing, Inc. In no case is merchandise to be returned to Axxiom for credit without authorization. At the time of authorization, Axxiom will issue a return authorization number that must be included on all packages and correspondence. Any material returned without prior authorization will remain the property of the sender and Axxiom will not be responsible for it.
6. All returns must be shipped prepaid freight. All returns may be exchanged for other equipment or parts of equal dollar value. If goods are not exchanged, they are subject to a 20% restocking charge. Any cost incurred by Axxiom Manufacturing, Inc. to restore such goods to first class condition will be charged to the customer.
7. Axxiom Manufacturing, Inc. reserves the right to inspect and make the final decision on any merchandise returned under warranty.
8. Axxiom Manufacturing, Inc. offers no warranty with respect to accessories, including but not limited to, engines, motors, batteries, tires and any other parts not manufactured by Axxiom Manufacturing, Inc., but which the original manufacturer warrants.

9. Axxiom Manufacturing, Inc. reserves the right to make product changes or improvements without prior notice and without imposing any obligation upon itself to install the same on its products previously sold.
10. The above warranty conditions can only be altered by Axxiom Manufacturing, Inc. Axxiom must confirm alterations in writing for each specific transaction.
11. Axxiom Manufacturing, Inc. reserves the right to establish specific warranty terms for used or demo machines on an individual transaction basis. Invoices covering such merchandise will clearly state the provisions of the applicable warranty for each specific transaction.
12. USE OF NON-ORIGINAL SCHMIDT® FACTORY REPLACEMENT PARTS ON ANY SCHMIDT EQUIPMENT VOIDS ALL WARRANTIES.
13. AXXIOM MANUFACTURING, INC. DOES NOT AUTHORIZE ANY PERSON, REPRESENTATIVE OR SERVICE OR SALES ORGANIZATION TO MAKE ANY OTHER WARRANTY OR TO ASSUME ON BEHALF OF AXXIOM MANUFACTURING, INC. ANY LIABILITY IN CONNECTION WITH THE SALE OF OUR PRODUCTS OTHER THAN THOSE CONTAINED HEREIN.
14. UNDER NO CIRCUMSTANCES SHALL AXXIOM MANUFACTURING, INC. BE LIABLE TO CUSTOMER OR ANY OTHER PERSON FOR ANY DIRECT, INCIDENTAL, OR CONSEQUENTIAL DAMAGES RESULTING FROM THE USE OF THE PRODUCT OR ARISING OUT OF ANY BREACH OF ANY WARRANTY OR FOR ANY SPECIAL OR CONSEQUENTIAL DAMAGES OF ANY CHARACTER, INCLUDING WITHOUT LIMITATIONS, DAMAGES FOR ANY LOSS OF GOODWILL, WORK STOPPAGE, OR ANY AND ALL OTHER COMMERCIAL DAMAGES OR LOSSES.
15. AXXIOM MANUFACTURING, INC. MAKES NO OTHER WARRANTIES, EXPRESSED OR IMPLIED, INCLUDING, BUT NOT LIMITED TO, THE IMPLIED WARRANTIES OF MERCHANTABILITY AND FITNESS FOR A PARTICULAR PURPOSE WITH RESPECT TO THE SCHMIDT PRODUCTS SOLD PURSUANT THERETO.

12.3 Trademarks, Patents, and Proprietary Statements

Schmidt, the Schmidt S logo, Thompson Valve, and Combo Valve are registered trademarks owned by Axxiom Manufacturing, Inc. Use of the Schmidt, the Schmidt S logo, Thompson Valve, and Combo Valve trademarks without the written consent of Axxiom Manufacturing is strictly prohibited.

Products manufactured and marketed by Axxiom Manufacturing, Inc. are protected by patents issued or pending in the United States and other countries.

The text, diagrams, and drawings contained in this manual are proprietary information intended solely for instruction in the operation of the specified equipment. Use of any text, diagrams, or drawings contained in this manual for any reason other than its intended purpose without the written consent of Axxiom Manufacturing, Inc. is strictly prohibited.

12.4 Safety Information Sources

Axxiom Manufacturing, Inc

This equipment and all Schmidt® equipment are manufactured exclusively by Axxiom Manufacturing, Inc. If any operational or safety related questions arise relating to this equipment contact Axxiom Manufacturing, Inc.

Phone: 1-800-231-2085

Website: www.axxiommfg.com

Axxiom Manufacturing, Inc.

11927 South Highway 6

Fresno, Texas 77459

Occupational Safety and Health Administration (OSHA) establishes and enforces regulations regarding safety practices in the workplace including the abrasive blasting industry. Any questions, reporting of work related injuries, or reporting of unsafe work practices can be made to the following contact information. Answers to most any safety related questions can be found at the OSHA website shown below.

Phone: 1-800-321-6742

Website: www.osha.gov

U.S. Department of Labor

Occupational Safety and Health Administration

200 Constitution Avenue

Washington D.C. 20210

National Institute of Occupational Safety and Health (NIOSH) is a federal agency responsible for conducting research and recommendations for the prevention of work related injuries and sickness.

Phone: 1-800-356-4674

Website: www.cdc.gov/niosh

National Institute of Occupational Safety and Health

Hubert H. Humphrey Bldg.

200 Independence Avenue, SW

Room 715H

Washington, DC 20201

American National Standards Institute (ANSI) coordinates the development and use of voluntary consensus standards including safety standards.

Phone: 1-202-293-8020

Website: www.ansi.org

American National Standards Institute

1819 L Street, NW

6th Floor

Washington, DC 20036

12.5 Surface Preparation Information Sources

The Society for Protective Coatings (SSPC) consists of research and testing committees, conducts seminars and establishes industry standards on surface preparation methods, abrasive and coatings.

Phone: 1-412-281-2331

Website: www.sspc.org

The Society for Protective Coatings
40 24th Street
Pittsburg, PA 15222-4643

National Association of Corrosion Engineers (NACE) develops test methods and recommended practices on surface preparation techniques and coatings.

Phone: 1-281-228-6200

Website: www.nace.org

National Association of Corrosion Engineers
1440 South Creek Drive
Houston, TX 77084

12.6 Table of Blast Abrasive Characteristics

Abrasive Type	Hardness (Mohs)	Grain Shape	Density Lbs/ft ³	Color	Free Silica Content	No. of Recycles	Initial Cost	Typical Use
Corn Cobs	2	angular	35-45	tan	none	4-5	low	stripping paint from delicate substrates
Sodium Bicarbonate	2.8	crystal	60	white	none	4-5	medium	cleaning and stripping paint from delicate substrates
Walnut Shell	3	angular	45	lt. brown	none	4.5	low	stripping paint from delicate substrates
Plastic	3.2	angular	45-60	white	none	8-10	medium	Paint stripping, deburring, and cleaning
Glass Beads	4.5	spherical	90	crystal	none	8-10	low	cleaning finishing
Starblast XL	6.5	spherical	100	lt. brown	<1%	4-5	medium	outdoor blasting
Coal Slag	7	angular	85	black	none	1-2	medium	outdoor blasting
Copper Slag	7	angular	112	black	none	1-2	medium	outdoor blasting
Garnet	7	angular	147	pink	<2%	4-5	medium	outdoor blasting
Steel Shot	8	spherical	280	steel grey	none	200	low	cleaning and peening
Steel Grit	8	angular	280	steel grey	none	200	medium	removing heavy scale
Aluminum Oxide	9	angular	120	brown	<1%	6-8	medium	cleaning and finishing, deburring and etching

NOTES

13.0 Blasting Data

13.1 Table 1 Approximate Air Consumption (cfm) Per Blast Nozzle

NOZZLE SIZE		NOZZLE PRESSURE						
		60 psi	70 psi	80 psi	90 psi	100 psi	120 psi	140 psi
No.2	1/8"	14	16	18	20	22	26	30
No.3	3/16"	32	36	41	45	49	58	66
No.4	1/4"	57	65	72	80	90	105	121
No.5	5/16"	90	101	113	125	140	160	185
No.6	3/8"	126	145	163	182	200	235	270
No.7	7/16"	170	193	215	240	270	315	360
No.8	1/2"	230	260	290	320	350	410	470
No.10	5/8"	360	406	454	500	550	640	740
No.12	3/4"	518	585	652	720	790	925	1060

13.2 Table 2 Abrasive Consumption (lbs. per hour) Per Blast Nozzle

NOZZLE SIZE		NOZZLE PRESSURE						
		60 psi	70 psi	80 psi	90 psi	100 psi	120 psi	140 psi
No.2	1/8"	90	105	115	130	140	165	190
No.3	3/16"	205	230	260	290	320	375	430
No.4	1/4"	365	420	460	500	560	660	760
No.5	5/16"	575	650	725	825	900	1050	1200
No.6	3/8"	840	945	1050	1155	1260	1475	1700
No.7	7/16"	1150	1300	1450	1600	1750	2050	2350
No.8	1/2"	1460	1660	1850	2000	2250	2650	3000
No.10	5/8"	2290	2600	2900	3125	3520	4100	4750
No.12	3/4"	3300	3750	4180	4500	5060	5950	6800

13.3 Table 3 Hose Selection Guide (blasting @ 100 Psi)

NOZZLE SIZE	No.4 1/4"	No.5 5/16"	No.6 3/8"	No.7 7/16"	No.8 1/2"
CFM @ 100psi	90	140	200	270	350
AIR HOSE	1 1/4"	1 1/4"	1 1/2"	1 1/2"	2"
BLAST HOSE	1"	1 1/4"	1 1/4"	1 1/2"	1 1/2"
ABRASIVE (lbs per hr)	560	900	1260	1750	2250

13.4 Additional Information on Blasting Productivity

Air volume and pressure are very important. The blasting production rate will increase with higher blasting pressures and decrease with lower blasting pressures. The National Association of Corrosion Engineers' data suggests that for each 1 psi reduction in nozzle pressure, there is a 1.5% production loss. Pressure drop through a Schmidt® blast unit is normally less than 1 psi, while blast units manufactured by some of our competitors have pressure losses as high as 12 psi resulting in an 18% loss of production. Air pressure loss can also be avoided by using the shortest possible hose of adequate size. The inside diameter of both the blast hose (other than whip hose) and the air hose should be approximately three times the diameter of the orifice in the blast nozzle.

Standard Schmidt blast units are rated for a maximum pressure of 125 psi although high pressure units rated for 150 psi are available on request.